

# Description and Handling

## 233, 236, 736, 737, 738, 739, 740 and 745 Series

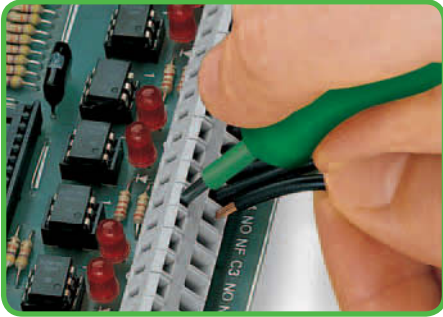

Inserting conductor via 3.5 mm screwdriver. Screwdriver actuation parallel to conductor entry.

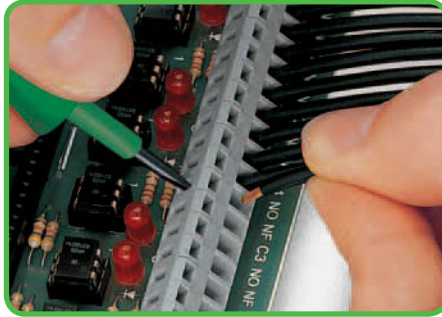

Inserting conductor via 3.5 mm screwdriver. Screwdriver actuation perpendicular to conductor entry.

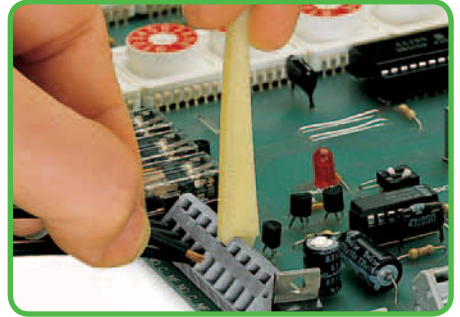

Inserting conductor via operating tool.

### Pin spacing combination

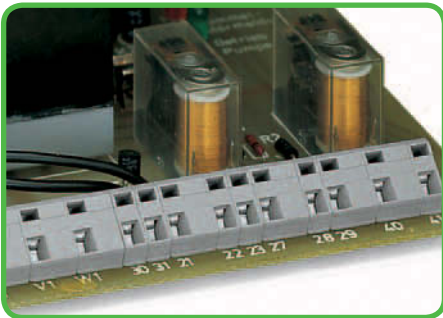

Combining terminal blocks with different pin spacing.

### 736 Series

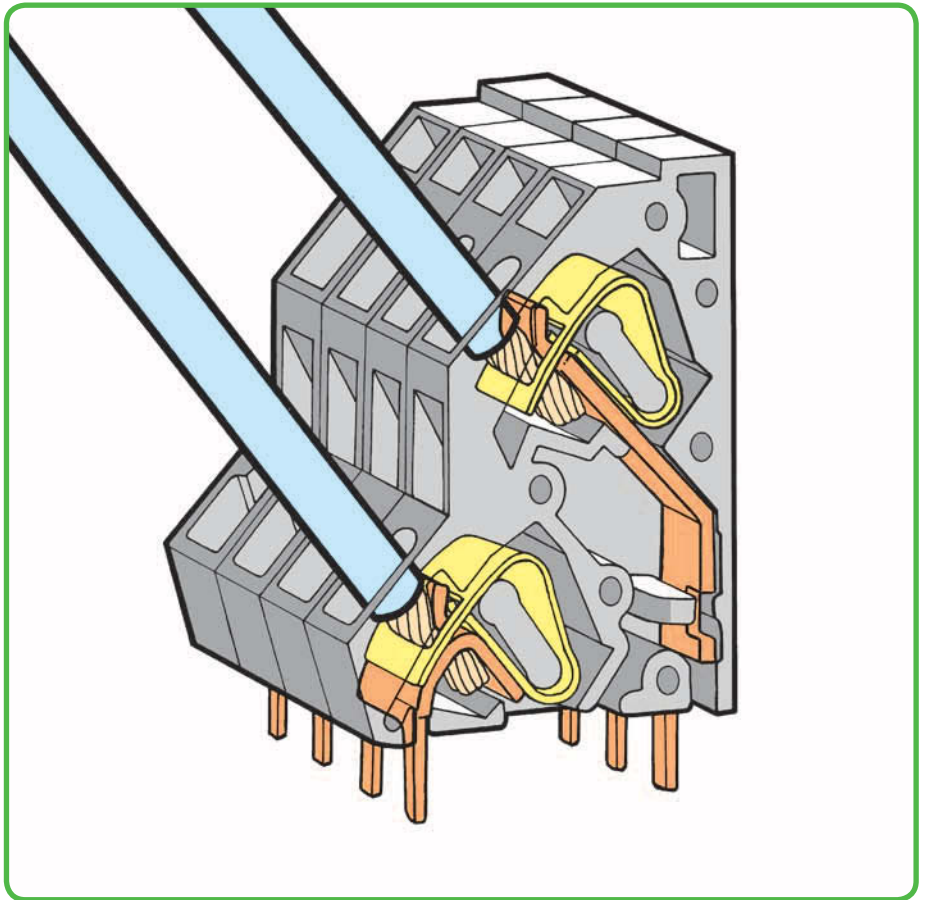

### Space-efficient configuration



Terminal strips placed behind each other save space – staggering them by half the pin spacing simplifies subsequent wiring of the first row.

### Marking

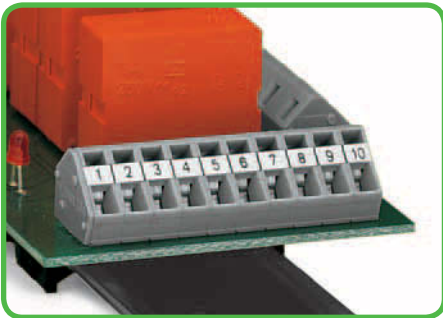

Marking via self-adhesive strips ...

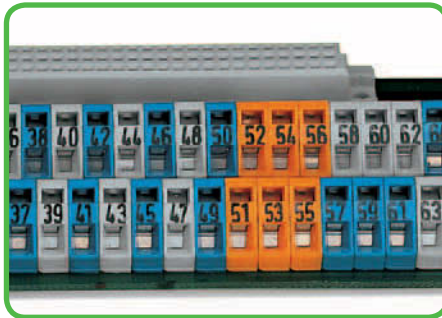

... or factory direct printing.

### Testing

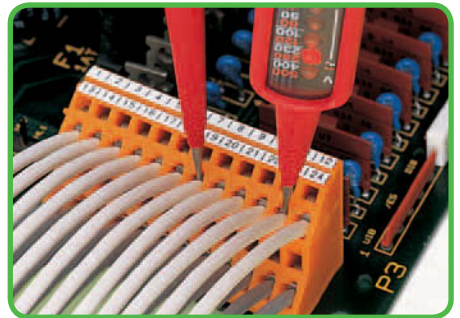

Testing via contact area above the conductors.



**CAGE CLAMP®** clamps the following copper conductors:\*

solid



stranded



fine-stranded, also with tinned single strands

\* For aluminum conductors, see notes in Section 11.



Inserting conductor perpendicular to screwdriver actuation - 740 Series.

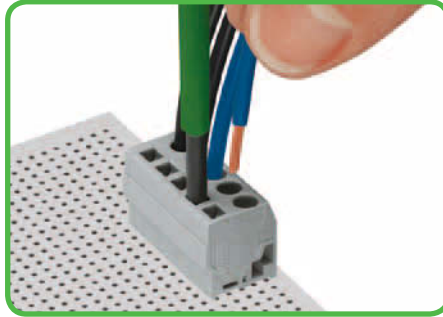

Inserting conductor parallel to screwdriver actuation - 739 Series.

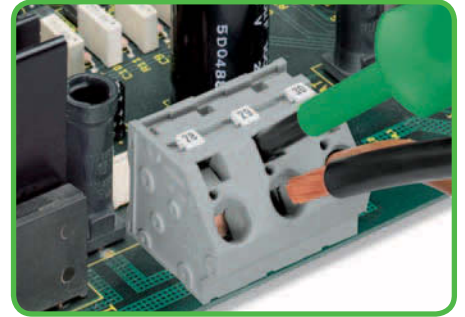

Inserting/removing conductor via 5.5 mm screwdriver - 745 Series, 16 mm².

745 Series

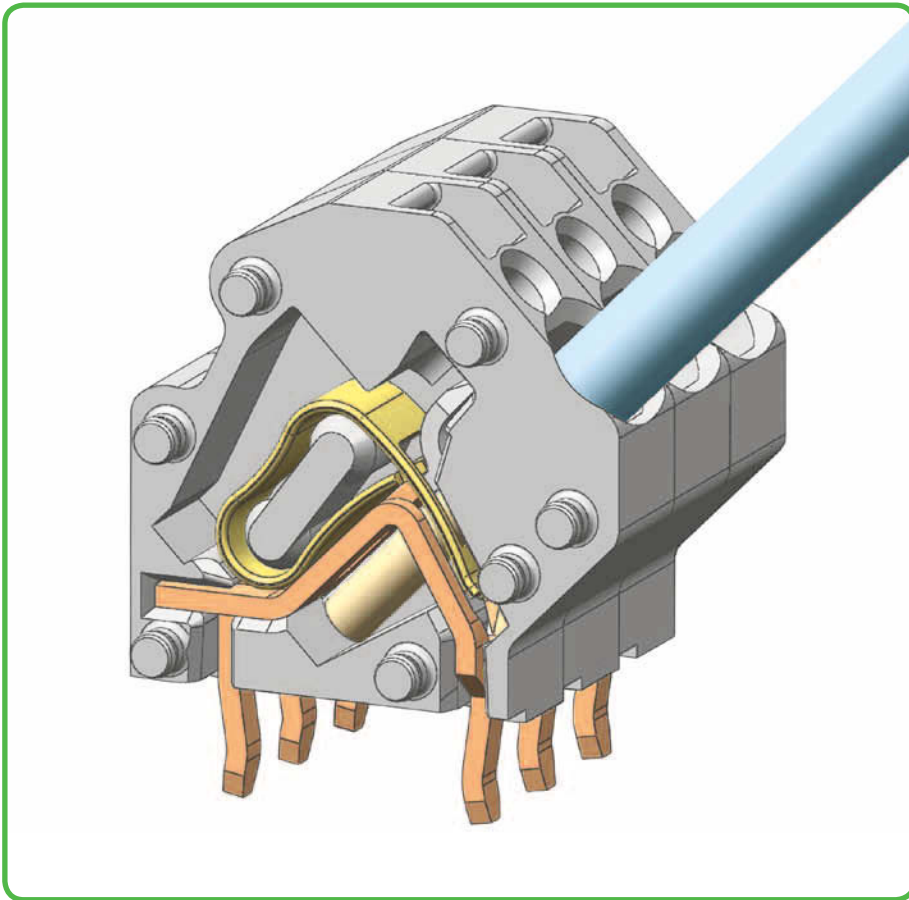

To insert comb-style jumper bar, push it down using a screwdriver until it hits the backstop - 745 Series.

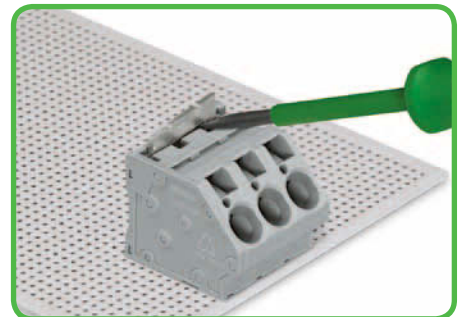

To remove comb-style jumper bar, lift it up using a screwdriver - 745 Series.

Space requirement

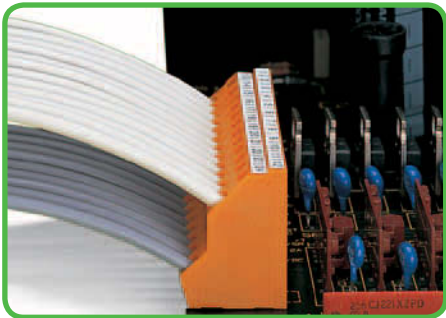

Low space requirements due to high-density design - double-deck terminal strip - 736 Series.

Marking

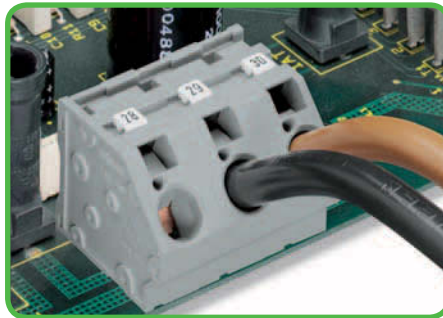

Marking with miniature WSB and WMB markers or factory direct printing - 745 Series.

Testing



Testing with test plug - 745 Series.



fine-stranded, tip-bonded



fine-stranded with crimped ferrules (gas-tight)

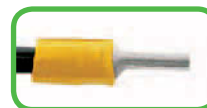

fine-stranded with crimped pin terminal (gas-tight)



# PCB Terminal Strips 0.5 mm<sup>2</sup> Pin Spacing 2.5 mm, 2.54 mm 233 Series

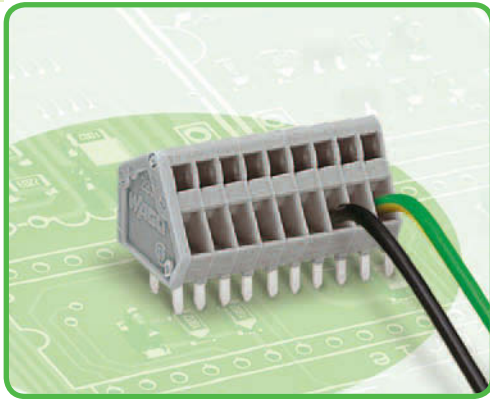

- Compact terminal strips with CAGE CLAMP® connection, screwdriver actuation parallel or perpendicular to conductor entry
- Double solder pins for high mechanical stability
- Custom color combinations
- For 233 Series with push-buttons, see page 89

**Technical data:**

Pin Spacing	2.5 mm 0.098 in			2.54 mm 0.1 in		
	IEC/EN 60664-1			IEC/EN 60664-1		
Rating per						
Overtoltage category	III	III	II	III	III	II
Pollution degree	3	2	2	3	2	2
Rated voltage	63 V	160 V	320 V	63 V	160 V	320 V
Rated surge voltage	2.5 kV	2.5 kV	2.5 kV	2.5 kV	2.5 kV	2.5 kV
Nominal current	6 A	6 A	6 A	6 A	6 A	6 A
Approvals per	UL/CSA			UL/CSA		
Use group UL 1059	B	C	D	B	C	D
Rated voltage	150 V	-	-	150 V	-	-
Nominal current UL	4 A	-	-	4 A	-	-
Nominal current CSA	4 A	-	-	4 A	-	-

**Conductor and solder pin data:**

Connection technology	CAGE CLAMP®
Conductor size: solid	0.08 - 0.5 mm <sup>2</sup> *
Conductor size: fine-stranded	0.08 - 0.5 mm <sup>2</sup> *
Conductor size: fine-stranded	0.25 mm <sup>2</sup> (with insulated ferrule)
Conductor size: fine-stranded	0.25 mm <sup>2</sup> (with uninsulated ferrule)
AWG	28 - 20
Strip length	5 - 6 mm / 0.20 - 0.24 in
Conductor entry angle	30° to PCB
Solder pin: length/width	4 mm / 0.5 x 0.75 mm
Solder pin: drilled hole diameter	1.1 <sup>+0.1</sup> mm

**Material data:**

Material group	I
Insulating material	Nylon 6.6 (PA 6.6)
Flammability rating per UL 94	V0
Lower/Upper temperature limit	-60°C / +105°C
Clamping spring material	Chrome-nickel spring steel (CrNi)
Contact material	Electrolytic copper (E <sub>Cu</sub> )
Contact plating	tin-plated

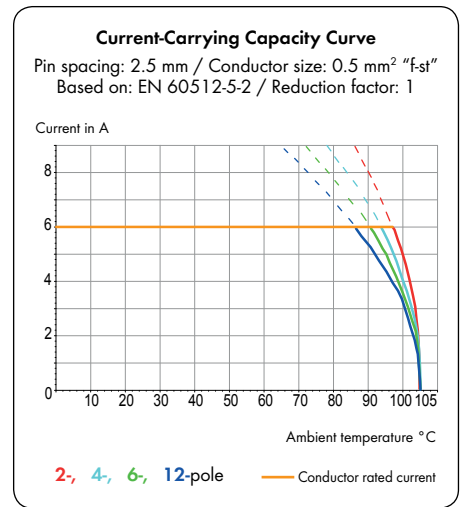

**233 Series accessories:**

**Page:**

Marking accessories	540 - 543
Operating tools	526 - 528

\* Terminating 0.75 mm<sup>2</sup> / AWG 18 conductors is possible; however insulation diameter does not allow clamping units to be terminated in a row.

Pin spacing 2.5 mm / 0.098 in		Pin spacing 2.54 mm / 0.1 in	
0.08 – 0.5 mm <sup>2</sup> 160 V/2.5 kV/2 6 A	AWG 28 – 20 150 V/4 A	0.08 – 0.5 mm <sup>2</sup> 160 V/2.5 kV/2 6 A	AWG 28 – 20 150 V/4 A

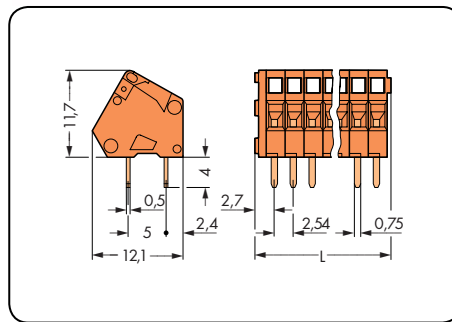
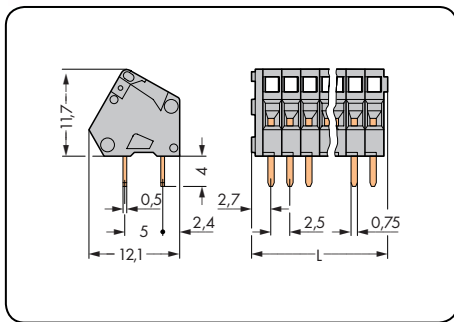

L = (pole no. x pin spacing) + 2.3 mm

Pole No.	Item No.	Pack. Unit	Pole No.	Item No.	Pack. Unit
<b>Terminal strip, 2 solder pins/pole, gray</b>			<b>Terminal strip, 2 solder pins/pole, orange</b>		
2	233-102	600 (6 x 100)	2	233-402	600 (6 x 100)
3	233-103	500 (4 x 125)	3	233-403	500 (4 x 125)
4	233-104	400 (4 x 100)	4	233-404	400 (4 x 100)
5	233-105	340 (4 x 85)	5	233-405	340 (4 x 85)
6	233-106	280 (4 x 70)	6	233-406	280 (4 x 70)
7	233-107	240 (4 x 60)	7	233-407	240 (4 x 60)
8	233-108	220 (4 x 55)	8	233-408	220 (4 x 55)
9	233-109	200 (4 x 50)	9	233-409	200 (4 x 50)
10	233-110	180 (4 x 45)	10	233-410	180 (4 x 45)
12	233-112	140 (4 x 35)	12	233-412	140 (4 x 35)
16	233-116	100 (4 x 25)	16	233-416	100 (4 x 25)
24	233-124	80 (4 x 20)	24	233-424	80 (4 x 20)
<b>Item No. Suffix: Colored Terminal Strips (Production and prices depend on quantity required)</b>			<b>Item No. Suffix: Colored Terminal Strips (Production and prices depend on quantity required)</b>		
● light green	...-.../000-017		● yellow	...-.../000-002	
● red	...-.../000-005		● black	...-.../000-004	
● green	...-.../000-023		● blue	...-.../000-006	
			● brown	...-.../000-014	
<b>Ordering example:</b> Terminal strip, 2.5 mm pin spacing, 8-pole, green: <b>233-108/000-023</b>			<b>Ordering example:</b> Terminal strip, 2.54 mm pin spacing, 8-pole, brown: <b>233-408/000-014</b>		

# Modular PCB Terminal Blocks 2.5 mm<sup>2</sup> Pin Spacing 5/5.08 mm, 7.5/7.62 mm, 10/10.16 mm 236 Series



- Modular terminal blocks with CAGE CLAMP® connection, screwdriver actuation parallel or perpendicular to conductor entry
- versions with Ex e (increased safety) approval
- For custom terminal strip assemblies
- Operating tools for factory wiring
- 45° conductor entry angle provides a wide variety of applications and wiring options
- Set to metric or inch pin spacing by compressing terminal strips together or pulling them apart

### Technical data:

Pin Spacing	5/5.08 mm 0.2 in			7.5/7.62 mm 0.3 in			10/10.16 mm 0.4 in		
	IEC/EN 60664-1			IEC/EN 60664-1			IEC/EN 60664-1		
Rating per	III III II			III III II			III III II		
Overtoltage category	III III II			III III II			III III II		
Pollution degree	3	2	2	3	2	2	3	2	2
Rated voltage	250 V	320 V	630 V	400 V	630 V	1000 V	630 V	1000 V	1000 V
Rated surge voltage	4 kV	4 kV	4 kV	6 kV	6 kV	6 kV	8 kV	8 kV	8 kV
Nominal current	24 A	24 A	24 A	24 A	24 A	24 A	24 A	24 A	24 A
Approvals per	UL/CSA			UL/CSA			UL/CSA		
Use group UL 1059	B	C	D	B	C	D	B	C	D
Rated voltage	300 V	-	300 V	300 V	-	300 V	300 V	-	300 V
Nominal current UL	15 A	-	10 A	15 A	-	10 A	15 A	-	10 A
Nominal current CSA	15 A	-	10 A	15 A	-	10 A	15 A	-	10 A

### Conductor and solder pin data:

Connection technology	CAGE CLAMP®
Conductor size: solid	0.08 - 2.5 mm <sup>2</sup>
Conductor size: fine-stranded	0.08 - 2.5 mm <sup>2</sup>
Conductor size: fine-stranded	0.25 - 1.5 mm <sup>2</sup> (with insulated ferrule)
Conductor size: fine-stranded	0.25 - 1.5 mm <sup>2</sup> (with uninsulated ferrule)
AWG	28 - 12 (12: THHN, THWN)
Strip length	5 - 6 mm / 0.20 - 0.24 in
Conductor entry angle	45° to PCB
Solder pin: length/width	4 (3.6; 5.5) mm / 0.7 x 0.7 mm
Solder pin: drilled hole diameter	1.1 <sup>+0.1</sup> mm

### Material data:

Material group	I
Insulating material	Nylon 6.6 (PA 6.6)
Flammability rating per UL 94	V0
Lower/Upper temperature limit	-60°C / +105°C
Clamping spring material	Chrome-nickel spring steel (CrNi)
Contact material	Electrolytic copper (E <sub>Cu</sub> )
Contact plating	tin-plated

### Technical data for Ex e II () versions:

Pin Spacing	5/5.08 mm 0.2 in	7.5/7.62 mm 0.3 in	10/10.16 mm 0.4 in
Rating per	ATEX: PTB 06 ATEX 1061 U IECEx: PTB 06.0042 U		
Rated voltage	176 V	275 V	440 V
Nominal current	16 A	16 A	16 A

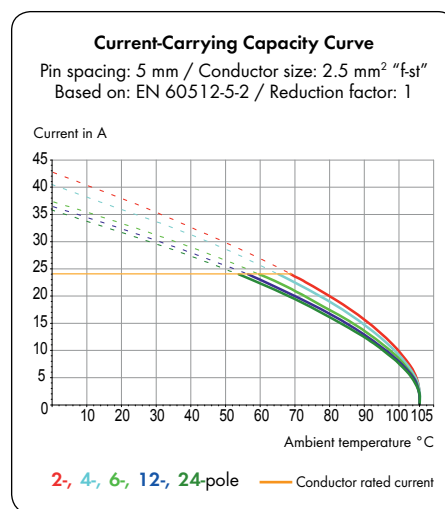

### 236 Series accessories:

### Page:

Marking accessories	540 - 543
Operating tools	526 - 528
Commoning strips	67 - 69
Test plug modules	199

# Modular PCB Terminal Blocks 2.5 mm<sup>2</sup>

CAGE CLAMP®

Pin spacing 5/5.08 mm / 0.2 in		Pin spacing 7.5/7.62 mm / 0.3 in		Pin spacing 10/10.16 mm / 0.4 in	
0.08 - 2.5 mm <sup>2</sup> 320 V/4 kV/2 24 A	AWG 28 - 12 300 V/10 A	0.08 - 2.5 mm <sup>2</sup> 630 V/6 kV/2 24 A	AWG 28 - 12 300 V/10 A	0.08 - 2.5 mm <sup>2</sup> 1000 V/8 kV/2 24 A	AWG 28 - 12 300 V/10 A

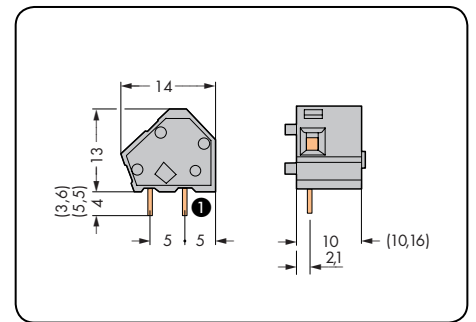
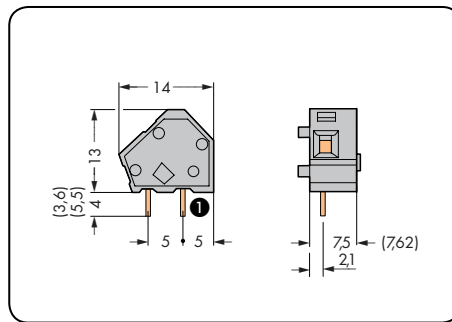
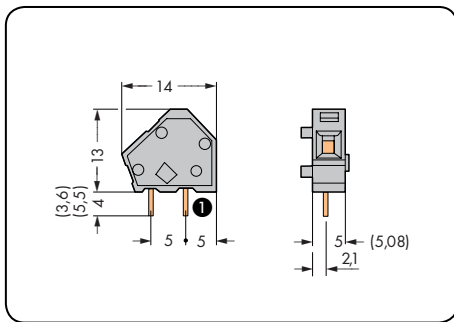

① Solder pin position for modular terminal block with one solder pin (rear side)

Color	Item No.	Item No.	Pack. Unit	Color	Item No.	Item No.	Pack. Unit	Color	Item No.	Item No.	Pack. Unit
<b>Modular terminal block</b>				<b>Modular terminal block</b>				<b>Modular terminal block</b>			
1 solder pin/pole		2 solder pins/pole		1 solder pin/pole		2 solder pins/pole		1 solder pin/pole		2 solder pins/pole	
gray	236-101	236-401	600 (6 x 100)	gray	236-201	236-501	400 (4 x 100)	gray	236-301	236-601	300 (3 x 100)
red	236-710	236-740	600 (6 x 100)	dark gray	236-722	236-752	400 (4 x 100)	dark gray	236-732	236-762	300 (3 x 100)
yellow	236-711	236-741	600 (6 x 100)	light gray	236-723	236-753	400 (4 x 100)	light gray	236-733	236-763	300 (3 x 100)
dark gray	236-712	236-742	600 (6 x 100)	① blue	236-724	236-754	400 (4 x 100)	① blue	236-734	236-764	300 (3 x 100)
light gray	236-713	236-743	600 (6 x 100)	green	236-725	236-755	400 (4 x 100)	green	236-735	236-765	300 (3 x 100)
blue	236-714	236-744	600 (6 x 100)	orange	236-726	236-756	400 (4 x 100)	orange	236-736	236-766	300 (3 x 100)
green	236-715	236-745	600 (6 x 100)	light green	236-727	236-757	400 (4 x 100)	light green	236-737	236-767	300 (3 x 100)
orange	236-716	236-746	600 (6 x 100)	black	236-855	236-852	400 (4 x 100)	black	236-856	236-853	300 (3 x 100)
light green	236-717	236-747	600 (6 x 100)	brown	236-885	236-882	400 (4 x 100)				
purple	236-894	236-891	600 (6 x 100)								
black	236-854	236-851	600 (6 x 100)								
brown	236-884	236-881	600 (6 x 100)								
Ex e II	236-743/999-950			Ex e II	236-753/999-950			Ex e II	236-763/999-950		
				① Suitable for Ex i applications				① Suitable for Ex i applications			
Item no. suffix for 2 solder pins/pole with 3.6 mm long solder pins: . . . . . /334-000											
Item no. suffix for 2 solder pins/pole with 5.5 mm long solder pins: . . . . . /332-000											

End plates for 236 Series, snap-on type, 1 mm/0.039 in thick	Color	Item No.	Pack. Unit
	gray	236-100	100
	dark gray	236-200	100
	light gray	236-300	100
	blue	236-400	100
	green	236-500	100
	orange	236-600	100
	light green	236-700	100
	red	236-800	100
black	236-850	100	

For other colors, please contact factory.



# PCB Terminal Strips 2.5 mm<sup>2</sup> Pin Spacing 5/5.08 mm, 7.5/7.62 mm, 10/10.16 mm 236 Series



- Terminal strips with CAGE CLAMP® connection, screwdriver actuation parallel or perpendicular to conductor entry
- versions with Ex e (increased safety) approval
- Mixed-color terminal strips from factory
- Operating tools for factory wiring
- 45° conductor entry angle provides a wide variety of applications and wiring options
- Set to metric or inch pin spacing by compressing terminal strips together or pulling them apart

### Technical data:

Pin Spacing	5/5.08 mm 0.2 in			7.5/7.62 mm 0.3 in			10/10.16 mm 0.4 in		
Rating per	IEC/EN 60664-1			IEC/EN 60664-1			IEC/EN 60664-1		
Overtoltage category	III	III	II	III	III	II	III	III	II
Pollution degree	3	2	2	3	2	2	3	2	2
Rated voltage	250 V	320 V	630 V	400 V	630 V	1000 V	630 V	1000 V	1000 V
Rated surge voltage	4 kV	4 kV	4 kV	6 kV	6 kV	6 kV	8 kV	8 kV	8 kV
Nominal current	24 A	24 A	24 A	24 A	24 A	24 A	24 A	24 A	24 A
Approvals per	UL/CSA			UL/CSA			UL/CSA		
Use group UL 1059	B	C	D	B	C	D	B	C	D
Rated voltage	300 V	-	300 V	300 V	-	300 V	300 V	-	300 V
Nominal current UL	15 A	-	10 A	15 A	-	10 A	15 A	-	10 A
Nominal current CSA	15 A	-	10 A	15 A	-	10 A	15 A	-	10 A

### Conductor and solder pin data:

Connection technology	CAGE CLAMP®
Conductor size: solid	0.08 - 2.5 mm <sup>2</sup>
Conductor size: fine-stranded	0.08 - 2.5 mm <sup>2</sup>
Conductor size: fine-stranded	0.25 - 1.5 mm <sup>2</sup> (with insulated ferrule)
Conductor size: fine-stranded	0.25 - 1.5 mm <sup>2</sup> (with uninsulated ferrule)
AWG	28 - 12 (12: THHN, THWN)
Strip length	5 - 6 mm / 0.20 - 0.24 in
Conductor entry angle	45° to PCB
Solder pin: length/width	4 (3.6; 5.5) mm / 0.7 x 0.7 mm
Solder pin: drilled hole diameter	1.1 <sup>+0.1</sup> mm

### Material data:

Material group	I
Insulating material	Nylon 6.6 (PA 6.6)
Flammability rating per UL 94	V0
Lower/Upper temperature limit	-60°C / +105°C
Clamping spring material	Chrome-nickel spring steel (CrNi)
Contact material	Electrolytic copper (E <sub>Cu</sub> )
Contact plating	tin-plated

### Technical data for Ex e II () versions:

Pin Spacing	5/5.08 mm 0.2 in	7.5/7.62 mm 0.3 in	10/10.16 mm 0.4 in
Rating per	ATEX: PTB 06 ATEX 1061 U		IECEX: PTB 06.0042 U
Rated voltage	176 V	275 V	440 V
Nominal current	16 A	16 A	16 A

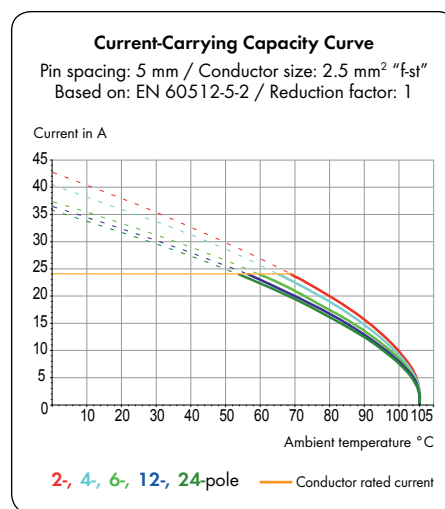

### 236 Series accessories:

### Page:

Marking accessories	540 - 543
Operating tools	526 - 528
Commoning strips	67 - 69
Test plug modules	198

Pin spacing 5/5.08 mm / 0.2 in		Pin spacing 7.5/7.62 mm / 0.3 in		Pin spacing 10/10.16 mm / 0.4 in	
0.08 – 2.5 mm <sup>2</sup> 320 V/4 kV/2 24 A	AWG 28 – 12 300 V/10 A	0.08 – 2.5 mm <sup>2</sup> 630 V/6 kV/2 24 A	AWG 28 – 12 300 V/10 A	0.08 – 2.5 mm <sup>2</sup> 1000 V/8 kV/2 24 A	AWG 28 – 12 300 V/10 A

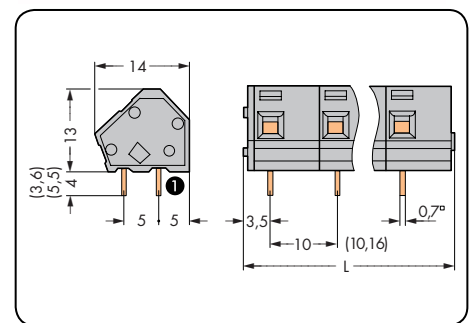
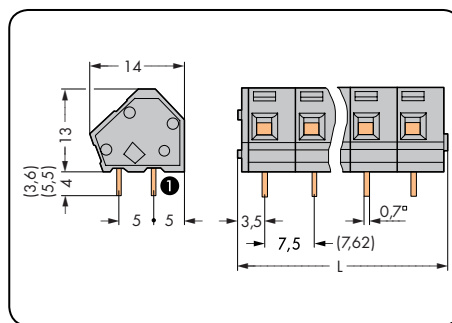
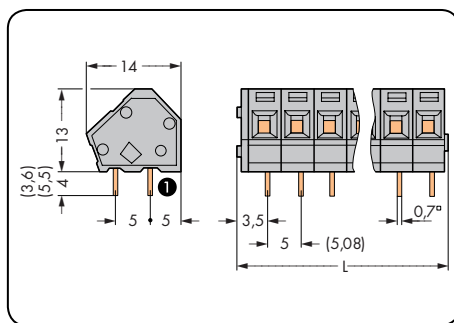
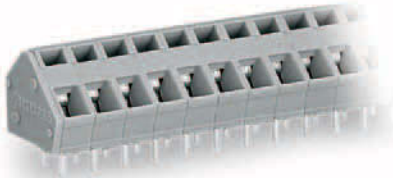

L = (pole no. x pin spacing) + 2.3 mm

① Solder pin position for modular terminal block with 1 solder pin (rear side)

Pole No.	Item No.	Item No.	Pack. Unit	Pole No.	Item No.	Item No.	Pack. Unit	Pole No.	Item No.	Item No.	Pack. Unit
<b>Terminal strip, 2 solder pins/pole, gray</b>				<b>Terminal strip, 2 solder pins/pole, gray</b>				<b>Terminal strip, 2 solder pins/pole, gray</b>			
<b>1 solder pin/pole</b>		<b>2 solder pins/pole</b>		<b>1 solder pin/pole</b>		<b>2 solder pins/pole</b>		<b>1 solder pin/pole</b>		<b>2 solder pins/pole</b>	
2	236-102	236-402	420 (4 x 105)	2	236-202	236-502	280 (4 x 70)	2	236-302	236-602	200 (4 x 50)
3	236-103	236-403	280 (4 x 70)	3	236-203	236-503	200 (4 x 50)	3	236-303	236-603	140 (4 x 35)
4	236-104	236-404	220 (4 x 55)	4	236-204	236-504	140 (4 x 35)	4	236-304	236-604	100 (4 x 25)
6	236-106	236-406	140 (4 x 35)	6	236-206	236-506	100 (4 x 25)	6	236-306	236-606	80 (4 x 20)
8	236-108	236-408	100 (4 x 25)	8	236-208	236-508	80 (4 x 20)	8	236-308	236-608	60 (4 x 15)
12	236-112	236-412	80 (4 x 20)	12	236-212	236-512	40 (4 x 10)	12	236-312	236-612	40 (4 x 10)
16	236-116	236-416	60 (4 x 15)	16	236-216	236-516	40 (4 x 10)	16	236-316	236-616	20 (4 x 5)
24	236-124	236-424	40 (4 x 10)	24	236-224	236-524	20 (4 x 5)	24	236-324	236-624	20 (4 x 5)
36	236-136	236-436	20 (4 x 5)								
48	236-148	236-448	20 (4 x 5)								
Item no. suffix for 2 solder pins/pole with 3.6 mm long solder pins: . . . . . /334-000											
Item no. suffix for 2 solder pins/pole with 5.5 mm long solder pins: . . . . . /332-000											

Item no. suffixes for Ex e II and Ex i applications:

○ Ex e II	. . . . . /000-009/999-950 (Ex e II only for PCB Terminal Strips with 2 solder pins/pole)	<b>Ordering example:</b> Terminal strip, 10/10.16 mm pin spacing, 8-pole, Ex e II: <b>236-608/000-009/999-950</b>
① Ex i	. . . . . /000-006 (only for 7.5/7.62 mm and 10/10.16 mm pin spacing)	

Item no. suffixes for colored terminal strips: (Production and prices depend on quantity required)

● black	. . . . . /000-004	<b>Ordering example:</b> Terminal strip, 5/5.08 mm pin spacing, 2 solder pins/pole 8-pole, orange: <b>236-408/000-012</b>
① blue	. . . . . /000-006	
● dark gray	. . . . . /000-008	
○ light gray	. . . . . /000-009	
● orange	. . . . . /000-012	
● light green	. . . . . /000-017	
● green	. . . . . /000-023	

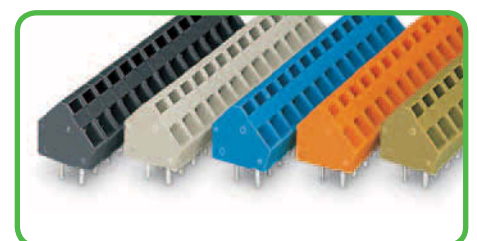



# PCB Terminal Strips 2.5 mm<sup>2</sup>, THR (Through-Hole Reflow\*)

## Pin Spacing 5 mm

### 236 Series

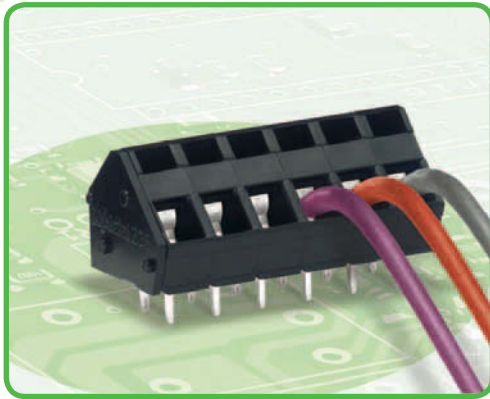

- Terminal strips made of high-temperature resistant plastic are suitable for SMT reflow soldering
- Tape-and-reel packaging
- Double solder pins for high mechanical stability

**Technical data:**

Pin Spacing	5 mm 0.197 in		
Rating per	IEC/EN 60664-1		
Overtoltage category	III	III	II
Pollution degree	3	2	2
Rated voltage	200 V	320 V	320 V
Rated surge voltage	4 kV	4 kV	4 kV
Nominal current	24 A	24 A	24 A
Approvals per	UL/CSA		
Use group UL 1059	B	C	D
Rated voltage	300 V	-	300 V
Nominal current UL	15 A	-	10 A
Nominal current CSA	15 A	-	10 A

**Conductor and solder pin data:**

Connection technology	CAGE CLAMP®
Conductor size: solid	0.08 - 2.5 mm <sup>2</sup>
Conductor size: fine-stranded	0.08 - 2.5 mm <sup>2</sup>
Conductor size: fine-stranded	0.25 - 1.5 mm <sup>2</sup> (with insulated ferrule)
Conductor size: fine-stranded	0.25 - 1.5 mm <sup>2</sup> (with uninsulated ferrule)
AWG	28 - 12 (12: THHN, THWN)
Strip length	5 - 6 mm / 0.20 - 0.24 in
Conductor entry angle	45° to PCB
Solder pin: length/width	3.6 mm / 0.7 x 0.7 mm
Solder pin: metal plated hole	Ø 1.1 <sup>+0.1</sup> mm

**Material data:**

Material group	III b
Insulating material	Nylon 4.6 (PA 4.6)
Flammability rating per UL 94	V2
Lower/Upper temperature limit	-60°C / +115°C
Clamping spring material	Chrome-nickel spring steel (CrNi)
Contact material	Electrolytic copper (E <sub>Cu</sub> )
Contact plating	tin-plated

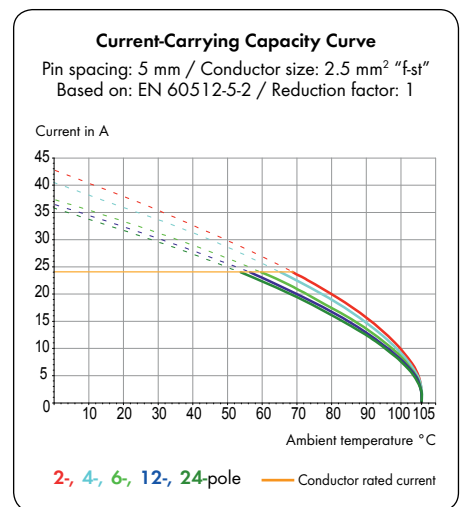

**236 Series accessories:**

**Page:**

Marking accessories	540 - 543
Operating tools	526 - 528
Test plug modules	198

<b>Pin spacing 5 mm / 0.197 in</b>		<b>Terminal strips in tape-and-reel packaging Pin spacing 5 mm / 0.197 in</b>		<b>THR (Through-Hole Reflow soldering)</b>
0.08 - 2.5 mm <sup>2</sup> 320 V/4 kV/2 24 A	AWG 28 - 12 300 V/10 A	0.08 - 2.5 mm <sup>2</sup> 320 V/4 kV/2 24 A	AWG 28 - 12 300 V/10 A	

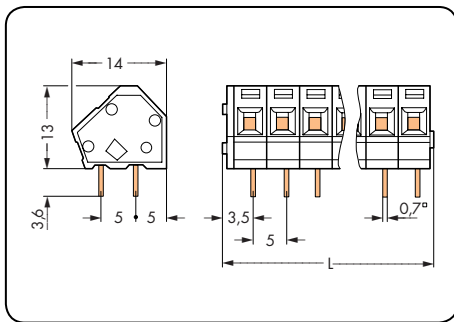
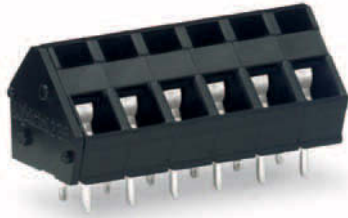

L = (pole no. x pin spacing) + 2.3 mm

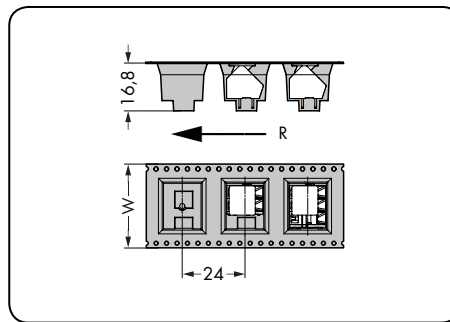

W = Tape width  
R = Feed direction

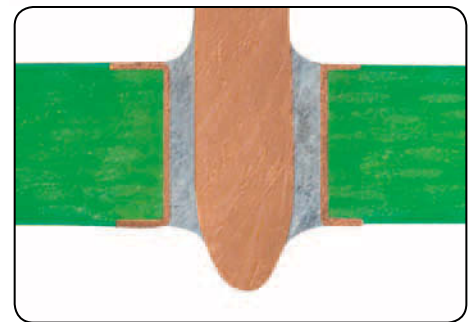

In electronic product manufacturing Surface Mount Technology has led to a rapid rise in productivity.

Pole No.	Item No.	Pack. Unit	Pole No.	Item No.	W (mm)
<b>Terminal strip, THR, 2 solder pins/pole, black</b>			<b>Terminal strips with additional suction pad in tape-and-reel packaging acc. to IEC 60286-3, black</b>		
2	236-402/334-604	420 (4 x 105)	2	236-402/334-604/997-405	32
3	236-403/334-604	280 (4 x 70)	3	236-403/334-604/997-405	32
4	236-404/334-604	220 (4 x 55)	4	236-404/334-604/997-406	44
5	236-405/334-604	180 (4 x 45)	5	236-405/334-604/997-406	44
6	236-406/334-604	140 (4 x 35)	6	236-406/334-604/997-406	44
Reel diameter: 330 mm, 120 pieces per reel					

The integration of standard electromechanical components such as connectors or PCB terminal blocks into the reflow soldering process provides an even greater potential for savings.

By using high-temperature resistant plastic and a streamlined pin design, the WAGO Through Hole Reflow connectors and PCB terminal blocks meet requirements for SMT process capability while maintaining necessary stability.

WAGO recommends both a temperature profile that adheres to EN 61760-1 and the use of forced convection ovens for processing THR components.

Series	d <sub>i</sub> (mm)	d <sub>A</sub> (mm)	H (mm)	d <sub>s</sub> (mm)	D <sub>s</sub> (µm)	d (mm)	L (mm)
734	1.4 <sup>+0.1</sup>	2.5	< 2	2.4	150	1.2	2.4
231	1.4 <sup>+0.1</sup>	2.5	< 2	2.4	150	1.2	2.4
236	1.1 <sup>+0.1</sup>	2.2	< 2	2.1	150	0.9	3.6
733	1.2 <sup>+0.1</sup>	1.9	< 2	1.8	150	1.0	2.4
218	1.1 <sup>+0.1</sup>	1.9	< 2	1.8	150	0.9	2.8
250	1.1 <sup>+0.1</sup>	2.0	< 2	1.9	150	0.9	3.6

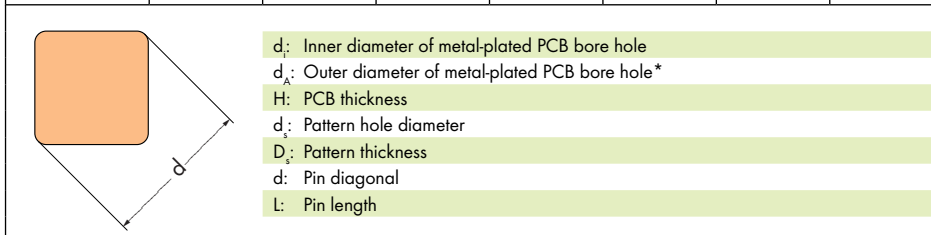

\* When laying out the metal-plated bore holes, the clearance and creepage distance requirements - as specified in the equipment standards - must be considered.

# 1 Modular PCB Terminal Blocks 4 mm<sup>2</sup> Pin Spacing 5 mm 745 Series

26



- Modular terminal blocks with screwdriver-actuated CAGE CLAMP® for custom terminal strip assemblies
- Ⓢ versions with Ex e (increased safety) approval
- Spacers for higher voltage applications
- Double solder pins for high mechanical stability
- Space-efficient configuration of terminal strips placed behind each other
- Integrated test port

### Technical data:

Pin Spacing	5 mm 0.197 in		
Rating per	IEC/EN 60664-1		
Overtension category	III	III	II
Pollution degree	3	2	2
Rated voltage	320 V	320 V	630 V
Rated surge voltage	4 kV	4 kV	4 kV
Nominal current	32 A	32 A	32 A
Approvals per	UL/CSA		
Use group UL 1059	B	C	D
Rated voltage	300 V	-	300 V
Nominal current UL	20 A	-	10 A
Nominal current CSA	20 A	-	10 A

### Conductor and solder pin data:

Connection technology	CAGE CLAMP®
Conductor size: solid	0.08 - 4 mm <sup>2</sup>
Conductor size: fine-stranded	0.08 - 4 mm <sup>2</sup>
Conductor size: fine-stranded	0.25 - 2.5 mm <sup>2</sup> (with insulated ferrule)
Conductor size: fine-stranded	0.25 - 2.5 mm <sup>2</sup> (with uninsulated ferrule)
AWG	28 - 12
Strip length	8 - 9 mm / 0.31 - 0.35 in
Conductor entry angle	45° to PCB
Solder pin: length/width	4 mm / 0.8 x 1.2 mm
Solder pin: drilled hole diameter	1.5 <sup>+0.1</sup> mm

### Material data:

Material group	I
Insulating material	Nylon 6.6 (PA 6.6)
Flammability rating per UL 94	V0
Lower/Upper temperature limit	-60°C / +105°C
Clamping spring material	Chrome-nickel spring steel (CrNi)
Contact material	Electrolytic copper (E <sub>Cu</sub> )
Contact plating	tin-plated

### Technical data for Ex e II (Ⓢ) versions:

Pin Spacing	5 mm 0.197 in	
Rating per	ATEX: PTB 06 ATEX 1014 U IECEx: IECEx PTB 06.0039 U	
Rated voltage	176 V	
Nominal current	27 A	

### Note on UL approval for 600 V:

The conductor entry is for field and factory wiring and meets spacing requirements for 600 V UL (Use Group: C). The solder pins are for factory wiring only. The suitability and spacing shall be evaluated in the end-use equipment, based on relevant end-product standard.

### Current-Carrying Capacity Curve

Pin spacing: 5 mm / Conductor size: 4 mm<sup>2</sup> "f-st"  
Based on: EN 60512-5-2 / Reduction factor: 1

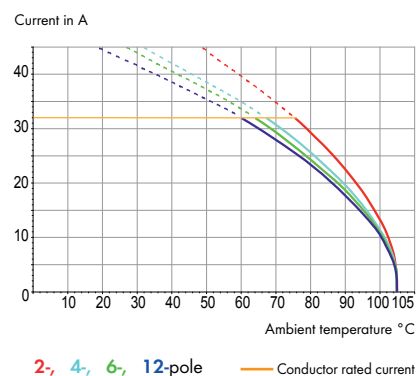



### 745 Series accessories:

### Page:

Marking accessories	540 - 543
Operating tools	526 - 528
Test plugs	538

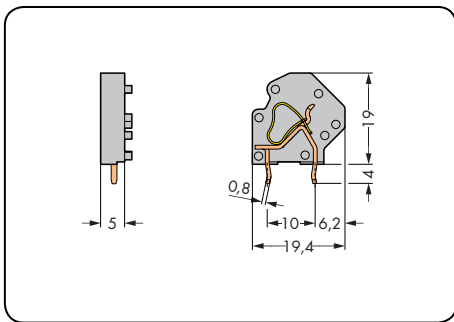
<b>Pin spacing 5 mm / 0.197 in</b>	
0.08 – 4 mm <sup>2</sup> 320 V/4 kV/2 32 A	AWG 28 – 12 300 V/10 A



Color	Item No.	Pack. Unit
<b>Modular terminal block, 2 solder pins/pole</b>		
gray	745-3801	200
light gray	745-3803	200
blue	745-3804	200
green-yellow	745-3807	200
light green	745-3808	200
Ex e II	745-3803/999-950	
<b>Product Accessories</b>		
<b>Spacer</b> for extending pin spacing, 2.5 mm thick, gray		
	745-3138	200 (4 x 50)

End plates, 745 Series	Item No.	Pack. Unit
	gray 745-3100	1000 (10 x 100)
	blue 745-3100/000-006	1000 (10 x 100)
	light gray 745-3100/000-009	1000 (10 x 100)
	green-yellow 745-3100/000-016	1000 (10 x 100)
	light green 745-3100/000-017	1000 (10 x 100)

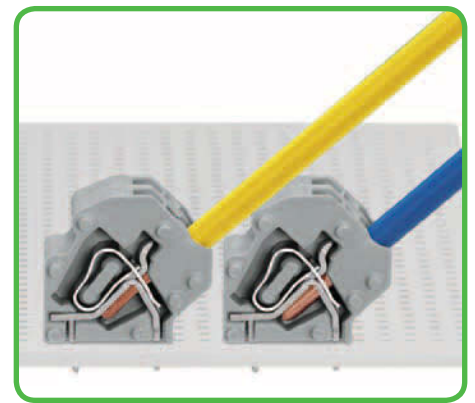

Saving space: 2 terminal strips arranged behind each other.

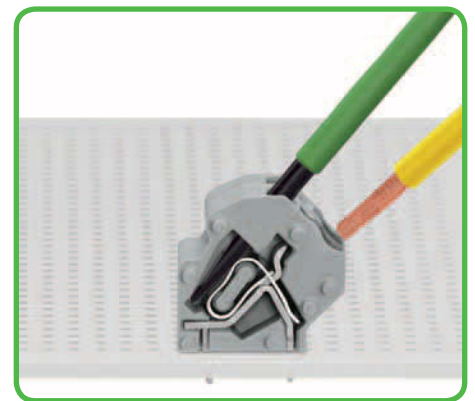

Inserting a conductor via 3.5 mm screwdriver.

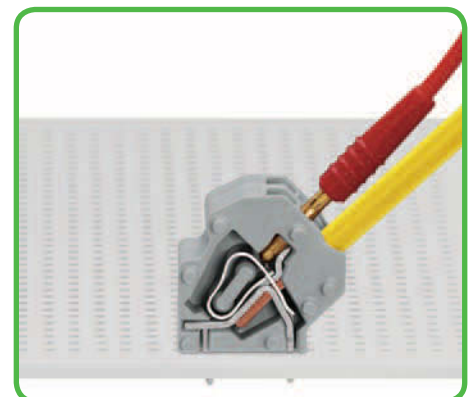

Testing with Ø 2 mm test plug.



# PCB Terminal Strips 4 mm<sup>2</sup> Pin Spacing 5 mm, 7.5 mm 745 Series



- Terminal strips with screwdriver-actuated CAGE CLAMP®
- versions with Ex e (increased safety) approval
- Space-efficient configuration of terminal strips placed behind each other
- Custom color combinations
- Double solder pins for high mechanical stability
- Integrated test ports

### Technical data:

Pin Spacing	5 mm 0.197 in			7.5 mm 0.295 in		
	IEC/EN 60664-1			IEC/EN 60664-1		
Rating per						
Overtoltage category	III	III	II	III	III	II
Pollution degree	3	2	2	3	2	2
Rated voltage	320 V	320 V	630 V	500 V	630 V	1000 V
Rated surge voltage	4 kV	4 kV	4 kV	6 kV	6 kV	6 kV
Nominal current	32 A	32 A	32 A	32 A	32 A	32 A
Approvals per	UL/CSA			UL/CSA		
Use group UL1059	B	C	D	B	C	D
Rated voltage	300 V	-	300 V	300 V	150 V	300 V
Nominal current UL	20 A	-	10 A	20 A	20 A	10 A
Nominal current CSA	20 A	-	10 A	20 A	20 A	10 A

### Conductor and solder pin data:

Connection technology	CAGE CLAMP®
Conductor size: solid	0.08 - 4 mm <sup>2</sup>
Conductor size: fine-stranded	0.08 - 4 mm <sup>2</sup>
Conductor size: fine-stranded	0.25 - 2.5 mm <sup>2</sup> (with insulated ferrule)
Conductor size: fine-stranded	0.25 - 2.5 mm <sup>2</sup> (with uninsulated ferrule)
AWG	28 - 12
Strip length	8 - 9 mm / 0.31 - 0.35 in
Conductor entry angle	45° to PCB
Solder pin: length/width	4 mm / 0.8 x 1.2 mm
Solder pin: drilled hole diameter	1.5 <sup>+0.1</sup> mm

### Material data:

Material group	I
Insulating material	Nylon 6.6 (PA 6.6)
Flammability rating per UL 94	V0
Lower/Upper temperature limit	-60°C / +105°C
Clamping spring material	Chrome-nickel spring steel (CrNi)
Contact material	Electrolytic copper (E <sub>cu</sub> )
Contact plating	tin-plated

### Technical data for Ex e II () versions:

Pin Spacing	5 mm 0.197 in	7.5 mm 0.295 in
	Rating per	ATEX: PTB 06 ATEX 1014 U IECEx: IECEx PTB 06.0039 U
Rated voltage	176 V	352 V
Nominal current	27 A	27 A

### Note on UL approval for 600 V:

The conductor entry is for field and factory wiring and meets spacing requirements for 600 V UL (Use Group: C). The solder pins are for factory wiring only. The suitability and spacing shall be evaluated in the end-use equipment, based on relevant end-product standard.

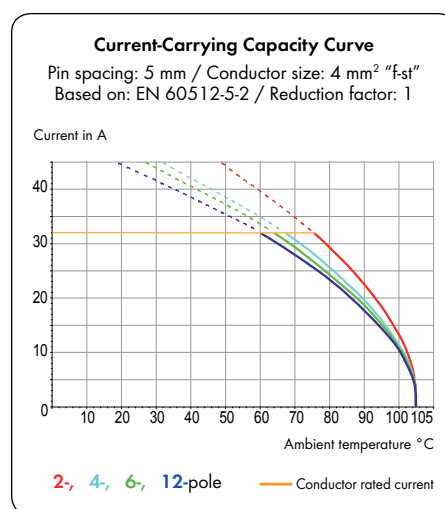

### 745 Series accessories:

### Page:

Marking accessories	540 - 543
Operating tools	526 - 528
Test plugs	538

Pin spacing 5 mm / 0.197 in		Pin spacing 7.5 / 0.295 in	
0.08 – 4 mm <sup>2</sup>	AWG 28 – 12	0.08 – 4 mm <sup>2</sup>	AWG 28 – 12
320 V/4 kV/2 32 A	300 V/10 A	630 V/6 kV/2 32 A	300 V/10 A

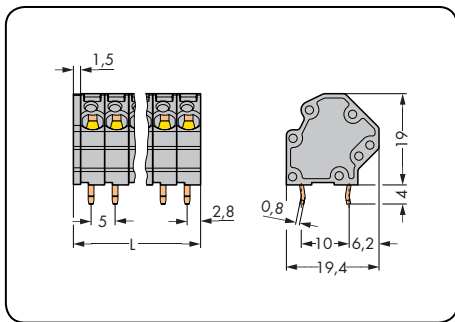

L = (pole no. x pin spacing) + 1.5 mm

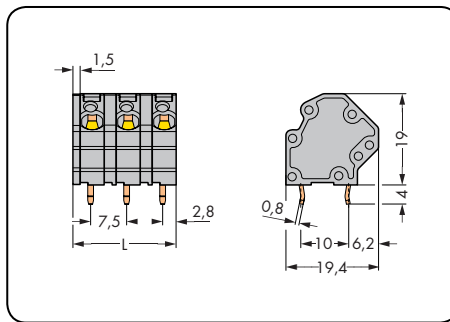

L = (pole no. - 1) x pin spacing + 5 mm + 1.5 mm

Pole No.	Item No.	Pack. Unit	Pole No.	Item No.	Pack. Unit
<b>Terminal strip, 2 solder pins/pole, gray</b>			<b>Terminal strip, 2 solder pins/pole, gray</b>		
2	745-3102	276	2	745-3152	228
3	745-3103	192	3	745-3153	144
4	745-3104	144	4	745-3154	108
5	745-3105	120	5	745-3155	84
6	745-3106	96	6	745-3156	72
7	745-3107	84	7	745-3157	60
8	745-3108	72	8	745-3158	48
9	745-3109	60	9	745-3159	48
10	745-3110	60	10	745-3160	36
11	745-3111	48	11	745-3161	36
12	745-3112	48	12	745-3162	36

**Item no. suffixes for Ex e II and Ex i applications:**

○ Ex e II ...-.../000-009/999-950	<b>Ordering example:</b>
● Ex i ...-.../000-006 (only for 7.5 mm pin spacing)	Terminal strip, 7.5 mm pin spacing,
	8-pole, Ex e II: <b>745-3158/000-009/999-950</b>

**Item no. suffixes for colored terminal strips: (Production and prices depend on quantity required)**

● blue ...-.../000-006	<b>Ordering example:</b>
○ light gray ...-.../000-009	Terminal strip, 5 mm pin spacing
● green-yellow ...-.../000-016	8-pole, light gray: <b>745-3108/000-009</b>
● light green ...-.../000-017	

# PCB Terminal Strips 4 mm<sup>2</sup> Pin Spacing 10 mm, 12.5 mm 745 Series

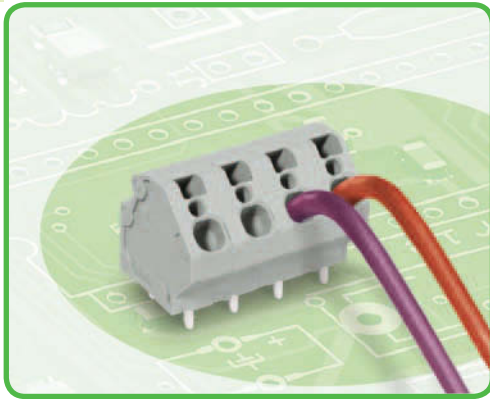

- Terminal strips with screwdriver-actuated CAGE CLAMP®
- versions with Ex e (increased safety) approval
- UL approval up to 600 V for 12.5 mm pin spacing
- Custom color combinations
- Double solder pins for high mechanical stability
- Integrated test ports

**Technical data:**

Pin Spacing	10 mm 0.394 in			12.5 mm 0.492 in		
	IEC/EN 60664-1			IEC/EN 60664-1		
Rating per	IEC/EN 60664-1			IEC/EN 60664-1		
Overtoltage category	III	III	II	III	III	II
Pollution degree	3	2	2	3	2	2
Rated voltage	800 V	1000 V	1000 V	1000 V	1000 V	1000 V
Rated surge voltage	8 kV	8 kV	8 kV	8 kV	8 kV	8 kV
Nominal current	32 A	32 A	32 A	32 A	32 A	32 A
Approvals per	UL/CSA			UL/CSA		
Use group UL1059	B	C	D	B	C	D
Rated voltage	300 V	300 V	600 V	600 V	600 V	-
Nominal current UL	20 A	20 A	5 A	20 A	20 A	-
Nominal current CSA	20 A	20 A	5 A	20 A	20 A	-

**Conductor and solder pin data:**

Connection technology	CAGE CLAMP®
Conductor size: solid	0.08 - 4 mm <sup>2</sup>
Conductor size: fine-stranded	0.08 - 4 mm <sup>2</sup>
Conductor size: fine-stranded	0.25 - 2.5 mm <sup>2</sup> (with insulated ferrule)
Conductor size: fine-stranded	0.25 - 2.5 mm <sup>2</sup> (with uninsulated ferrule)
AWG	28 - 12
Strip length	8 - 9 mm / 0.31 - 0.35 in
Conductor entry angle	45° to PCB
Solder pin: length/width	4 mm / 0.8 x 1.2 mm
Solder pin: drilled hole diameter	1.5 <sup>+0.1</sup> mm

**Material data:**

Material group	I
Insulating material	Nylon 6.6 (PA 6.6)
Flammability rating per UL 94	V0
Lower/Upper temperature limit	-60°C / +105°C
Clamping spring material	Chrome-nickel spring steel (CrNi)
Contact material	Electrolytic copper (E <sub>Cu</sub> )
Contact plating	tin-plated

**Technical data for Ex e II ( ) versions:**

Pin Spacing	10 mm 0.394 in	12.5 mm 0.492 in
Rating per	ATEX: PTB 06 ATEX 1014 U IECEx: IECEx PTB 06.0039 U	
Rated voltage	440 V	550 V
Nominal current	27 A	27 A

**Note on UL approval for 600 V:**

The conductor entry is for field and factory wiring and meets spacing requirements for 600 V UL (Use Group: C). The solder pins are for factory wiring only. The suitability and spacing shall be evaluated in the end-use equipment, based on relevant end-product standard.

**Current-Carrying Capacity Curve**

Pin spacing: 5 mm / Conductor size: 4 mm<sup>2</sup> "f-st"  
Based on: EN 60512-5-2 / Reduction factor: 1

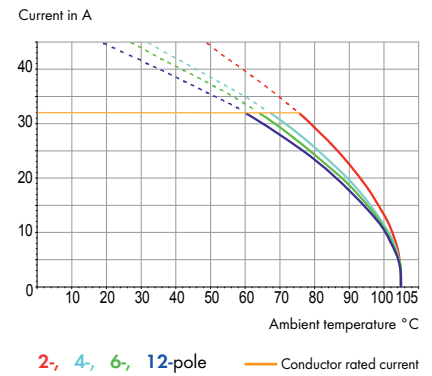

**745 Series accessories:**

**Page:**

Marking accessories	540 - 543
Operating tools	526 - 528
Test plugs	538

Pin spacing 10 mm / 0.394 in		Pin spacing 12.5 mm / 0.492 in	
0.08 – 4 mm <sup>2</sup>	AWG 28 – 12	0.08 – 4 mm <sup>2</sup>	AWG 28 – 12
1000 V/8 kV/2 32 A	300 V/20 A	1000 V/8 kV/2 32 A	600 V/20 A

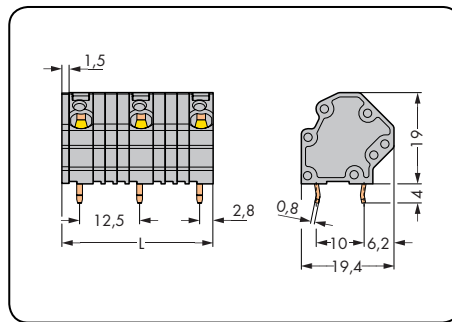
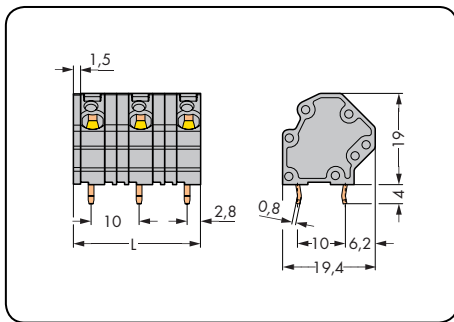

L = (pole no. - 1) x pin spacing + 5 mm + 1.5 mm

Pole No.	Item No.	Pack. Unit	Pole No.	Item No.	Pack. Unit
<b>Terminal strip, 2 solder pins/pole, gray</b>			<b>Terminal strip, 2 solder pins/pole, gray</b>		
2	745-3202	192	2	745-3252	168
3	745-3203	120	3	745-3253	96
4	745-3204	84	4	745-3254	72
5	745-3205	60	5	745-3255	48
6	745-3206	48	6	745-3256	36
7	745-3207	48	7	745-3257	36
8	745-3208	36	8	745-3258	24
9	745-3209	36	9	745-3259	24
10	745-3210	24	10	745-3260	24
11	745-3211	24	11	745-3261	24
12	745-3212	24	12	745-3262	12

**Item no. suffixes for Ex e II and Ex i applications:**

○ Ex e II	...../000-009/999-950	<b>Ordering example:</b>
● Ex i	...../000-006	Terminal strip, 12.5 mm pin spacing
		8-pole, Ex e II: <b>745-3258/000-009/999-950</b>

**Item no. suffixes for colored terminal strips: (Production and prices depend on quantity required)**

● blue	...../000-006	<b>Ordering example:</b>
○ light gray	...../000-009	Terminal strip, 10 mm pin spacing
● green-yellow	...../000-016	8-pole, light gray: <b>745-3208/000-009</b>
● light green	...../000-017	



# Modular PCB Terminal Blocks with Jumper Slots 4 mm<sup>2</sup> Pin Spacing 5 mm, 7.5 mm, 10 mm 745 Series

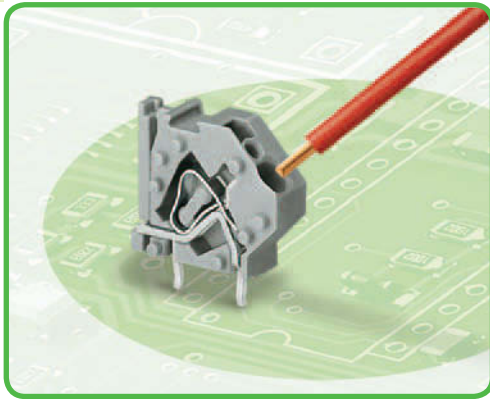

- Modular terminal blocks with screwdriver-actuated CAGE CLAMP® for custom terminal strip assemblies
- versions with Ex e (increased safety) approval
- Comb-style jumper bars for commoning and distributing potentials
- Double solder pins for high mechanical stability
- Integrated test port
- Marker slot for miniature WSB markers

**Technical data:**

Pin Spacing	5 mm 0.197 in			7.5 mm 0.295 in			10 mm 0.394 in		
Rating per	IEC/EN 60664-1			IEC/EN 60664-1			IEC/EN 60664-1		
Overtoltage category	III	III	II	III	III	II	III	III	II
Pollution degree	3	2	2	3	2	2	3	2	2
Rated voltage	320 V	320 V	630 V	500 V	630 V	1000 V	630 V	1000 V	1000 V
Rated surge voltage	4 kV	4 kV	4 kV	6 kV	6 kV	6 kV	8 kV	8 kV	8 kV
Nominal current	32 A	32 A	32 A	32 A	32 A	32 A	32 A	32 A	32 A
Approvals per	UL/CSA			UL/CSA			UL/CSA		
Use group UL1059	B	C	D	B	C	D	B	C	D
Rated voltage	300 V	-	300 V	300 V	150 V	300 V	300 V	150 V	300 V
Nominal current UL	20 A	-	10 A	20 A	20 A	10 A	20 A	20 A	10 A
Nominal current CSA	20 A	-	10 A	20 A	20 A	10 A	20 A	20 A	10 A

**Conductor and solder pin data:**

Connection technology	CAGE CLAMP®
Conductor size: solid	0.08 - 4 mm <sup>2</sup>
Conductor size: fine-stranded	0.08 - 4 mm <sup>2</sup>
Conductor size: fine-stranded	0.25 - 2.5 mm <sup>2</sup> (with insulated ferrule)
Conductor size: fine-stranded	0.25 - 2.5 mm <sup>2</sup> (with uninsulated ferrule)
AWG	28 - 12
Strip length	8 - 9 mm / 0.31 - 0.35 in
Conductor entry angle	45° to PCB
Solder pin: length/width	4 mm / 0.8 x 1.2 mm
Solder pin: drilled hole diameter	1.5 <sup>+0.1</sup> mm

**Material data:**

Material group	I
Insulating material	Nylon 6.6 (PA 6.6)
Flammability rating per UL 94	V0
Lower/Upper temperature limit	-60°C / +105°C
Clamping spring material	Chrome-nickel spring steel (CrNi)
Contact material	Electrolytic copper (E <sub>Cu</sub> )
Contact plating	tin-plated

**Technical data for Ex e II ( ) versions:**

Pin Spacing	5 mm 0.197 in	7.5 mm 0.295 in	10 mm 0.394 in
Rating per	ATEX: PTB 06 ATEX 1014 U IECEx: IECEx PTB 06.0039 U		
Rated voltage	176 V	352 V	440 V
Nominal current without jumpers	27 A	27 A	27 A
Nominal current with jumpers	21 A	21 A	21 A

**Note on UL approval for 600 V:**

The conductor entry is for field and factory wiring and meets spacing requirements for 600 V UL (Use Group: C). The solder pins are for factory wiring only. The suitability and spacing shall be evaluated in the end-use equipment, based on relevant end-product standard.

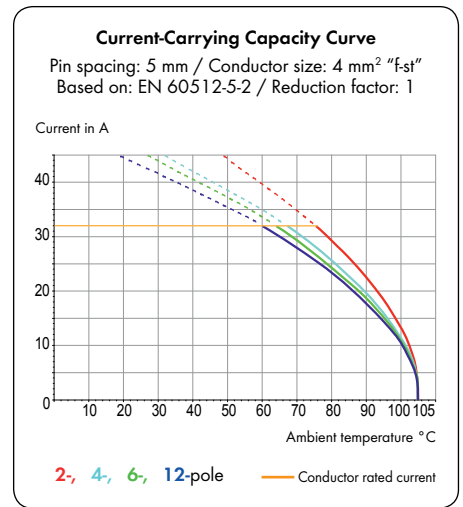

**745 Series accessories:**

**Page:**

Marking accessories	540 - 543
Operating tools	526 - 528
Comb-style jumper bars	197
Test plugs	538

Pin spacing 5 mm / 0.197 in		Pin spacing 7.5 mm / 0.295 in		Pin spacing 10 mm / 0.394 in	
0.08 – 4 mm <sup>2</sup> 320 V/4 kV/2 32 A	AWG 28 – 12 300 V/10 A	0.08 – 4 mm <sup>2</sup> 630 V/6 kV/2 32 A	AWG 28 – 12 300 V/10 A	0.08 – 4 mm <sup>2</sup> 1000 V/8 kV/2 32 A	AWG 28 – 12 300 V/10 A

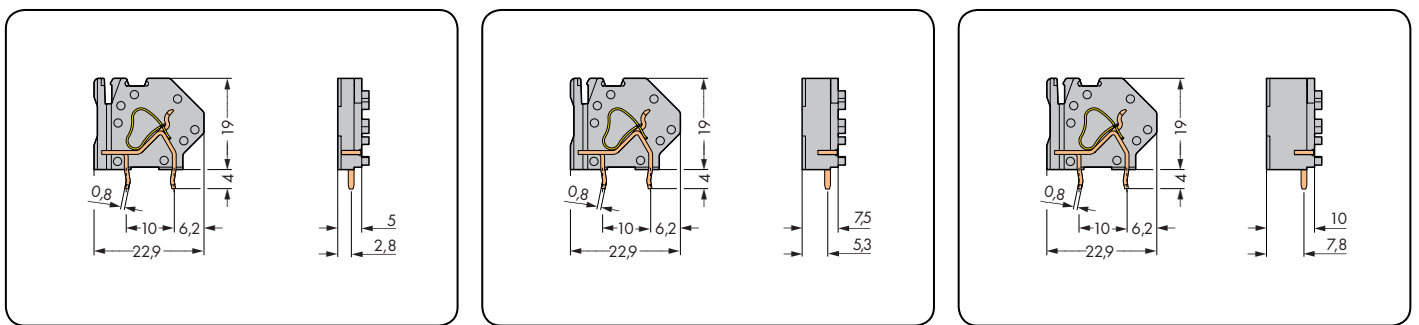

Color	Item No.	Pack. Unit	Color	Item No.	Pack. Unit	Color	Item No.	Pack. Unit
<b>Modular terminal block with jumper slot, 2 solder pins/pole</b>			<b>Modular terminal block with jumper slot, 2 solder pins/pole</b>			<b>Modular terminal block with jumper slot, 2 solder pins/pole</b>		
● gray	<b>745-801</b>	200 (4 x 50)	● gray	<b>745-811</b>	200 (4 x 50)	● gray	<b>745-821</b>	200 (4 x 50)
● light gray	<b>745-803</b>	200 (4 x 50)	● light gray	<b>745-813</b>	200 (4 x 50)	● light gray	<b>745-823</b>	200 (4 x 50)
① blue	<b>745-804</b>	200 (4 x 50)	① blue	<b>745-814</b>	200 (4 x 50)	① blue	<b>745-824</b>	200 (4 x 50)
● green-yellow	<b>745-807</b>	200 (4 x 50)	● green-yellow	<b>745-817</b>	200 (4 x 50)	● green-yellow	<b>745-827</b>	200 (4 x 50)
● light green	<b>745-808</b>	200 (4 x 50)	● light green	<b>745-818</b>	200 (4 x 50)	● light green	<b>745-828</b>	200 (4 x 50)
○ Ex e II	<b>745-803/999-950</b>		○ Ex e II	<b>745-813/999-950</b>		○ Ex e II	<b>745-823/999-950</b>	
			① Suitable for Ex i applications			① Suitable for Ex i applications		

End plates, 745 Series – 4 mm <sup>2</sup>	Item No.	Pack. Unit
	<b>745-100</b>	1000 (10 x 100)
	<b>745-140</b>	500 (5 x 100)
	<b>745-145</b>	500 (5 x 100)
<b>Item no. suffixes for end plates in different colors:</b>		
● blue	...../000-006	<b>Ordering example:</b> End plate with fixing flange, light gray: <b>745-140/000-009</b>
● light gray	...../000-009	
● green-yellow	...../000-016	
● light green	...../000-017	

# PCB Terminal Strips with Jumper Slots 4 mm<sup>2</sup> Pin Spacing 5 mm, 7.5 mm, 10 mm 745 Series



- Terminal strips with screwdriver-actuated CAGE CLAMP®
- versions with Ex e (increased safety) approval
- Comb-style jumper bars for commoning and distributing potentials
- Custom color combinations
- Double solder pins for high mechanical stability
- Integrated test ports
- Marker slot for miniature WSB markers

### Technical data:

Pin Spacing	5 mm 0.197 in			7.5 mm 0.295 in			10 mm 0.394 in		
	IEC/EN 60664-1			IEC/EN 60664-1			IEC/EN 60664-1		
Rating per	III III II			III III II			III III II		
Overtoltage category	3 2 2			3 2 2			3 2 2		
Pollution degree	3 2 2			3 2 2			3 2 2		
Rated voltage*	320 V	320 V	630 V	500 V	630 V	1000 V	630 V	1000 V	1000 V
Rated surge voltage	4 kV	4 kV	4 kV	6 kV	6 kV	6 kV	8 kV	8 kV	8 kV
Nominal current	32 A	32 A	32 A	32 A	32 A	32 A	32 A	32 A	32 A
Approvals per	UL/CSA			UL/CSA			UL/CSA		
Use group UL1059	B	C	D	B	C	D	B	C	D
Rated voltage	300 V	-	300 V	300 V	150 V	300 V	300 V	150 V	300 V
Nominal current UL	20 A	-	10 A	20 A	20 A	10 A	20 A	20 A	10 A
Nominal current CSA	20 A	-	10 A	20 A	20 A	10 A	20 A	20 A	10 A

### Conductor and solder pin data:

Connection technology	CAGE CLAMP®
Conductor size: solid	0.08 - 4 mm <sup>2</sup>
Conductor size: fine-stranded	0.08 - 4 mm <sup>2</sup>
Conductor size: fine-stranded	0.25 - 2.5 mm <sup>2</sup> (with insulated ferrule)
Conductor size: fine-stranded	0.25 - 2.5 mm <sup>2</sup> (with uninsulated ferrule)
AWG	28 - 12
Strip length	8 - 9 mm / 0.31 - 0.35 in
Conductor entry angle	45° to PCB
Solder pin: length/width	4 mm / 0.8 x 1.2 mm
Solder pin: drilled hole diameter	1.5 <sup>+0.1</sup> mm

### Material data:

Material group	I
Insulating material	Nylon 6.6 (PA 6.6)
Flammability rating per UL 94	V0
Lower/Upper temperature limit	-60°C / +105°C
Clamping spring material	Chrome-nickel spring steel (CrNi)
Contact material	Electrolytic copper (E <sub>Cu</sub> )
Contact plating	tin-plated

### Technical data for Ex e II () versions:

Pin Spacing	5 mm 0.197 in	7.5 mm 0.295 in	10 mm 0.394 in
Rating per	ATEX: PTB 06 ATEX 1014 U IECEx: IECEx PTB 06.0039 U		
Rated voltage	176 V	352 V	440 V
Nominal current without jumpers	27 A	27 A	27 A
Nominal current with jumpers	21 A	21 A	21 A

\* Using adjacent jumpers, the rated voltage is reduced to 250 V with 5 mm pin spacing in Category III/3 and to 400 V with 7.5 mm pin spacing in Category III/3.

### Note on UL approval for 600 V:

The conductor entry is for field and factory wiring and meets spacing requirements for 600 V UL (Use Group: C). The solder pins are for factory wiring only. The suitability and spacing shall be evaluated in the end-use equipment, based on relevant end-product standard.

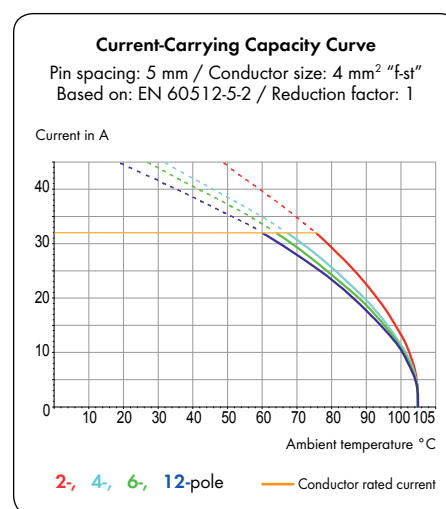

### 745 Series accessories:

### Page:

Marking accessories	540 - 543
Operating tools	526 - 528
Comb-style jumper bars	197
Test plugs	538

# PCB Terminal Strips with Jumper Slots 4 mm<sup>2</sup>

CAGE CLAMP®

Pin spacing 5 mm / 0.197 in		Pin spacing 7.5 mm / 0.295 in		Pin spacing 10 mm / 0.394 in	
0.08 – 4 mm <sup>2</sup>	AWG 28 – 12	0.08 – 4 mm <sup>2</sup>	AWG 28 – 12	0.08 – 4 mm <sup>2</sup>	AWG 28 – 12
320 V/4 kV/2 32 A	300 V/10 A	630 V/6 kV/2 32 A	300 V/10 A	1000 V/8 kV/2 32 A	300 V/10 A

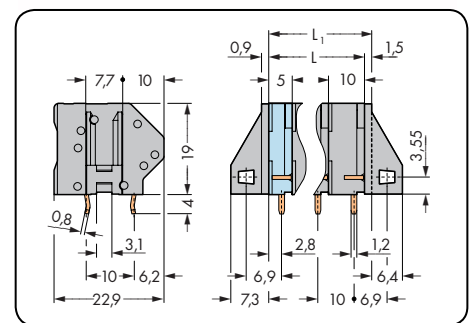
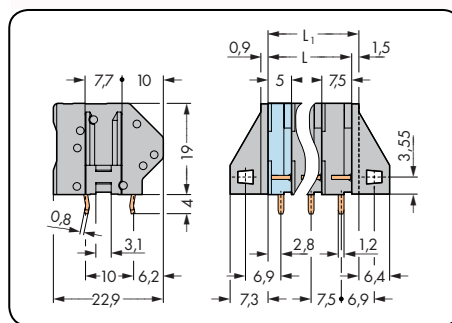
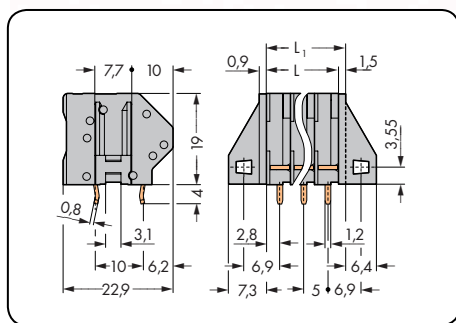
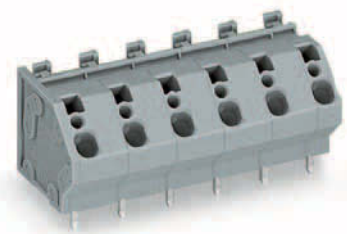
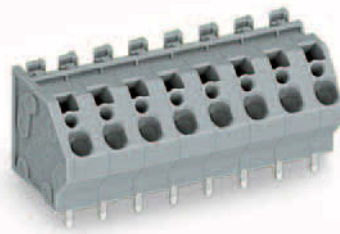
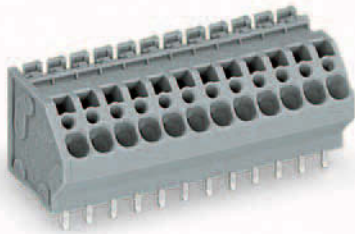

L = (pole no. - 1) x pin spacing + 5 mm  
L<sub>1</sub> = L + 1.5 mm  $\triangleq$  without fixing flanges

Pole No.	Item No.	Pack. Unit	Pole No.	Item No.	Pack. Unit	Pole No.	Item No.	Pack. Unit
<b>Terminal strip with jumper slot, 2 solder pins/pole, gray</b>			<b>Terminal strip with jumper slot, 2 solder pins/pole, gray</b>			<b>Terminal strip with jumper slot, 2 solder pins/pole, gray</b>		
2	745-102	230	2	745-152	180	2	745-202	160
3	745-103	160	3	745-153	120	3	745-203	100
4	745-104	120	4	745-154	90	4	745-204	70
5	745-105	100	5	745-155	70	5	745-205	50
6	745-106	80	6	745-156	60	6	745-206	40
7	745-107	70	7	745-157	50	7	745-207	40
8	745-108	60	8	745-158	40	8	745-208	30
9	745-109	50	9	745-159	40	9	745-209	30
10	745-110	50	10	745-160	30	10	745-210	20
12	745-112	40	12	745-162	30	12	745-212	20

Item no. suffix for terminal strips with fixing flanges: ...../005-000

Item no. suffixes for Ex e II and Ex i applications:

○ Ex e II	...../000-009/999-950	<b>Ordering examples:</b> Terminal strip with fixing flanges, 10 mm pin spacing, 8-pole, Ex e II: 745-208/005-009/999-950
● Ex i	...../000-006 (only for 7.5 mm and 10 mm pin spacing)	

Item no. suffixes for colored terminal strips: (Production and prices depend on quantity required)

● black	...../000-004	<b>Ordering examples:</b> Terminal strip without fixing flanges, 5 mm pin spacing, 8-pole, light gray: 745-108/000-009 (...../000-... without fixing flanges)
● blue	...../000-006	
○ light gray	...../000-009	Terminal strip with fixing flanges, 5 mm pin spacing, 8-pole, light gray: 745-108/005-009 (...../005-... with fixing flanges)
● green-yellow	...../000-016	
● light green	...../000-017	
● green	...../000-023	



# Modular PCB Terminal Blocks with Jumper Slots 6 mm<sup>2</sup> Pin Spacing 7.5 mm, 10 mm 745 Series



- Modular terminal blocks with screwdriver-actuated CAGE CLAMP® for custom terminal strip assemblies
- versions with Ex e (increased safety) approval
- Comb-style jumper bars for commoning and distributing potentials
- Spacers for higher voltage applications
- Double solder pins for high mechanical stability
- Integrated test port
- Marker slot for miniature WSB and WMB markers

### Technical data:

Pin Spacing	7.5 mm 0.295 in			10 mm 0.394 in		
Rating per	IEC/EN 60664-1			IEC/EN 60664-1		
Overtoltage category	III	III	II	III	III	II
Pollution degree	3	2	2	3	2	2
Rated voltage	500 V	630 V	1000 V	630 V	1000 V	1000 V
Rated surge voltage	6 kV	6 kV	6 kV	8 kV	8 kV	8 kV
Nominal current	41 A	41 A	41 A	41 A	41 A	41 A
Approvals per	UL/CSA			UL/CSA		
Use group UL1059	B	C	D	B	C	D
Rated voltage	300 V	150 V	300 V	300 V	150 V	300 V
Nominal current UL	30 A	30 A	10 A	30 A	30 A	10 A
Nominal current CSA	30 A	30 A	10 A	30 A	30 A	10 A

### Conductor and solder pin data:

Connection technology	CAGE CLAMP®
Conductor size: solid	0.2 - 6 mm <sup>2</sup>
Conductor size: fine-stranded	0.2 - 6 mm <sup>2</sup>
Conductor size: fine-stranded	0.25 - 4 mm <sup>2</sup> (with insulated ferrule)
Conductor size: fine-stranded	0.25 - 4 mm <sup>2</sup> (with uninsulated ferrule)
AWG	24 - 10
Strip length	11 - 12 mm / 0.39 - 0.43 in
Conductor entry angle	45° to PCB
Solder pin: length/width	4.5 mm / 1 x 1.4 mm
Solder pin: drilled hole diameter	1.8 <sup>+0.1</sup> mm

### Material data:

Material group	I
Insulating material	Nylon 6.6 (PA 6.6)
Flammability rating per UL 94	V0
Lower/Upper temperature limit	-60°C / +105°C
Clamping spring material	Chrome-nickel spring steel (CrNi)
Contact material	Electrolytic copper (E <sub>Cu</sub> )
Contact plating	tin-plated

### Technical data for Ex e II () versions:

Pin Spacing	7.5 mm 0.295 in	10 mm 0.394 in
Rating per	ATEX: PTB 06 ATEX 1014 U IECEx: IECEx PTB 06.00039 U	
Rated voltage	275 V	440 V
Nominal current without jumpers	37 A	37 A
Nominal current with jumpers	31 A	31 A

### Note on UL approval for 600 V:

The conductor entry is for field and factory wiring and meets spacing requirements for 600 V UL (Use Group: C). The solder pins are for factory wiring only. The suitability and spacing shall be evaluated in the end-use equipment, based on relevant end-product standard.

### Current-Carrying Capacity Curve

Pin spacing: 7.5 mm / Conductor size: 6 mm<sup>2</sup> "f-st"  
Based on: EN 60512-5-2 / Reduction factor: 1

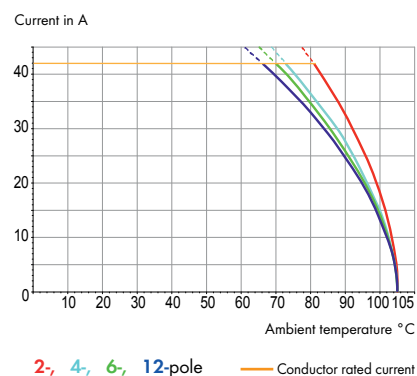



### 745 Series accessories:

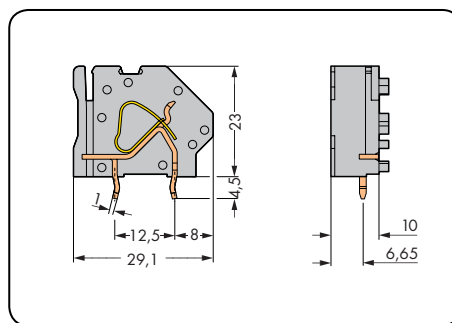
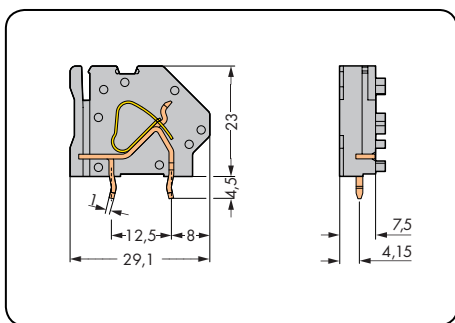

### Page:

Marking accessories	540 - 543
Operating tools	526 - 528
Comb-style jumper bars	197
Test plugs	538

Pin spacing 7.5 mm / 0.295 in		Pin spacing 10 mm / 0.394 in	
0.2 – 6 mm <sup>2</sup>	AWG 24 – 10	0.2 – 6 mm <sup>2</sup>	AWG 24 – 10
630 V/6 kV/2 41 A	300 V/10 A	1000 V/8 kV/2 41 A	300 V/10 A



Color	Item No.	Pack. Unit	Color	Item No.	Pack. Unit
<b>Modular terminal block with jumper slot, 2 solder pins/pole</b>			<b>Modular terminal block with jumper slot, 2 solder pins/pole</b>		
● gray	<b>745-831</b>	100 (2 x 50)	● gray	<b>745-841</b>	100 (2 x 50)
● light gray	<b>745-833</b>	100 (2 x 50)	● light gray	<b>745-843</b>	100 (2 x 50)
● blue	<b>745-834</b>	100 (2 x 50)	● blue	<b>745-844</b>	100 (2 x 50)
● green-yellow	<b>745-837</b>	100 (2 x 50)	● green-yellow	<b>745-847</b>	100 (2 x 50)
● light green	<b>745-838</b>	100 (2 x 50)	● light green	<b>745-848</b>	100 (2 x 50)
○ Ex e II	<b>745-833/999-950</b>		○ Ex e II	<b>745-843/999-950</b>	
① Suitable for Ex i applications			① Suitable for Ex i applications		
<b>Product Accessories</b>	<b>Item No.</b>	<b>Pack. Unit</b>			
<b>Spacer</b> (commoning via spacer is not possible) 2.5 mm thick, gray					
	<b>745-338</b>	500 (10 x 50)			

End plates, 745 Series – 6 mm <sup>2</sup>	Item No.	Pack. Unit
	End plate, snap-on type, 1.6 mm thick, gray	<b>745-300</b> 100
	End plate with fixing flange, gray	<b>745-340</b> 50
	End plate with fixing flange, gray	<b>745-345</b> 50
<b>Item no. suffixes for end plates in different colors:</b>		
● blue	... /000-006	<b>Ordering example:</b>
● light gray	... /000-009	End plate with fixing flange,
● green-yellow	... /000-016	light gray: <b>745-340/000-009</b>
● light green	... /000-017	

For other colors, please contact factory.

# 1 PCB Terminal Strips 6 mm<sup>2</sup> Pin Spacing 10 mm, 12.5 mm, 15 mm 745 Series

38

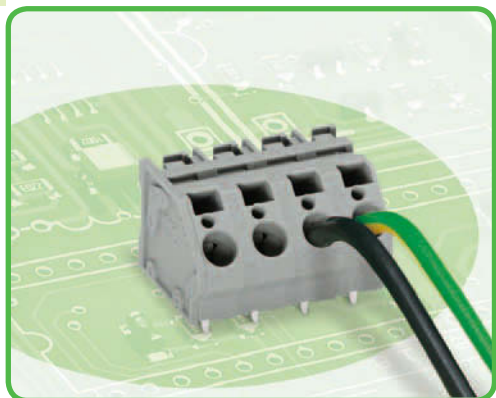

- Terminal strips with screwdriver-actuated CAGE CLAMP® (cannot be commoned!)
- Ex versions with Ex e (increased safety) approval
- UL approval up to 600 V for 12.5 mm pin spacing
- Custom color combinations
- Double solder pins for high mechanical stability
- Integrated test ports
- Marker slot for miniature WSB and WMB markers

### Technical data:

Pin Spacing	10 mm 0.394 in			12.5 mm 0.492 in			15 mm 0.591 in		
Rating per	IEC/EN 60664-1			IEC/EN 60664-1			IEC/EN 60664-1		
Overtoltage category	III	III	II	III	III	II	III	III	II
Pollution degree	3	2	2	3	2	2	3	2	2
Rated voltage	800 V	1000 V	1000 V	1000 V	1000 V	1000 V	1000 V	1000 V	1000 V
Rated surge voltage	8 kV	8 kV	8 kV	8 kV	8 kV	8 kV	8 kV	8 kV	8 kV
Nominal current	41 A	41 A	41 A	41 A	41 A	41 A	41 A	41 A	41 A
Approvals per	UL/CSA			UL/CSA			UL/CSA		
Use group UL1059	B	C	D	B	C	D	B	C	D
Rated voltage	300 V	300 V	600 V	600 V	600 V	-	600 V	600 V	-
Nominal current UL	10 A	10 A	5 A	30 A	30 A	-	30 A	30 A	-
Nominal current CSA	10 A	10 A	5 A	30 A	30 A	-	30 A	30 A	-

### Conductor and solder pin data:

Connection technology	CAGE CLAMP®
Conductor size: solid	0.2 - 6 mm <sup>2</sup>
Conductor size: fine-stranded	0.2 - 6 mm <sup>2</sup>
Conductor size: fine-stranded	0.25 - 4 mm <sup>2</sup> (with insulated ferrule)
Conductor size: fine-stranded	0.25 - 4 mm <sup>2</sup> (with uninsulated ferrule)
AWG	24 - 10
Strip length	11 - 12 mm / 0.43 - 0.47 in
Conductor entry angle	45° to PCB
Solder pin: length/width	4.5 mm / 1 x 1.4 mm
Solder pin: drilled hole diameter	1.8 <sup>+0.1</sup> mm

### Material data:

Material group	I
Insulating material	Nylon 6.6 (PA 6.6)
Flammability rating per UL 94	V0
Lower/Upper temperature limit	-60°C / +105°C
Clamping spring material	Chrome-nickel spring steel (CrNi)
Contact material	Electrolytic copper (E <sub>cu</sub> )
Contact plating	tin-plated

### Technical data for Ex e II (Ex) versions:

Pin Spacing	10 mm 0.394 in	12.5 mm 0.492 in	15 mm 0.591 in
Rating per	ATEX: PTB 06 ATEX 1014 U IECEx: IECEx PTB 06.0039 U		
Rated voltage	440 V	550 V	690 V
Nominal current	37 A	37 A	37 A

### Note on UL approval for 600 V:

The conductor entry is for field and factory wiring and meets spacing requirements for 600 V UL (Use Group: C). The solder pins are for factory wiring only. The suitability and spacing shall be evaluated in the end-use equipment, based on relevant end-product standard.

### Current-Carrying Capacity Curve

Pin spacing: 7.5 mm / Conductor size: 6 mm<sup>2</sup> "f-st"  
Based on: EN 60512-5-2 / Reduction factor: 1

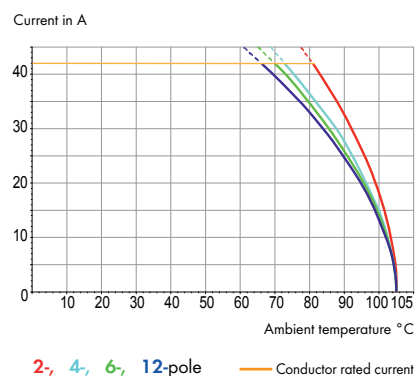

### 745 Series accessories:

Page:

Marking accessories	540 - 543
Operating tools	526 - 528
Test plugs	538

Pin spacing 10 mm / 0.394 in		Pin spacing 12.5 mm / 0.492 in		Pin spacing 15 mm / 0.591 in	
0.2 – 6 mm <sup>2</sup>	AWG 24 – 10	0.2 – 6 mm <sup>2</sup>	AWG 24 – 10	0.2 – 6 mm <sup>2</sup>	AWG 24 – 10
1000 V/8 kV/2 41 A	300 V/10 A	1000 V/8 kV/2 41 A	600 V/30 A	1000 V/8 kV/2 41 A	600 V/30 A

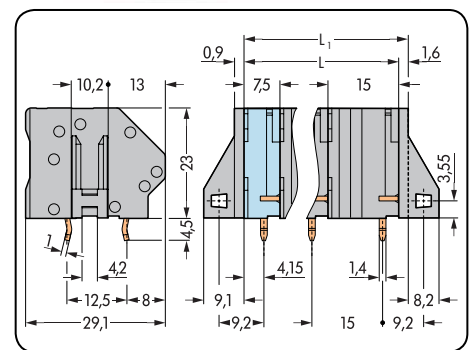
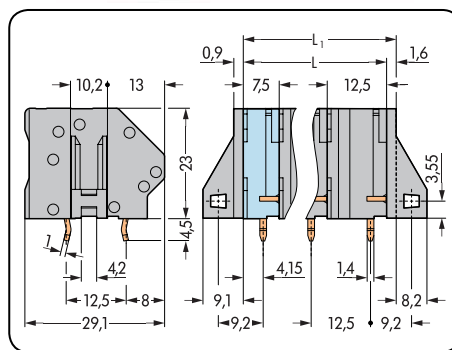
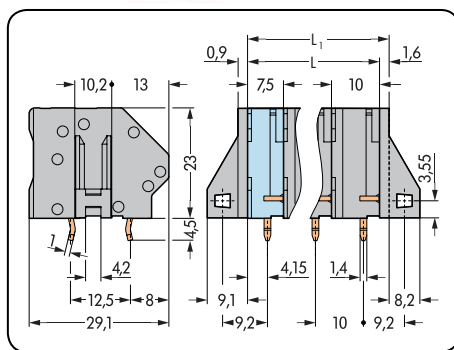

L = (pole no. - 1) x pin spacing + 7.5 mm  
 L<sub>1</sub> = L + 1.6 mm  $\hat{=}$  without fixing flanges

Pole No.	Item No.	Pack. Unit	Pole No.	Item No.	Pack. Unit	Pole No.	Item No.	Pack. Unit
Terminal strip, 2 solder pins/pole, gray			Terminal strip, 2 solder pins/pole, gray			Terminal strip, 2 solder pins/pole, gray		
2	745-1352	104	2	745-1402	80	2	745-1452	64
3	745-1353	72	3	745-1403	48	3	745-1453	40
4	745-1354	48	4	745-1404	40	4	745-1454	32
5	745-1355	40	5	745-1405	32	5	745-1455	24
6	745-1356	32	6	745-1406	24	6	745-1456	16
7	745-1357	24	7	745-1407	24	7	745-1457	16
8	745-1358	24	8	745-1408	16	8	745-1458	16
9	745-1359	24	9	745-1409	16	9	745-1459	8
10	745-1360	16	10	745-1410	16	10	745-1460	8
12	745-1362	16	12	745-1412	8	12	745-1462	8

Item no. suffix for terminal strips with fixing flanges: . . . . . /005-000

Item no. suffixes for Ex e II and Ex i applications:

○ Ex e II	. . . . . /000-009/999-950	<b>Ordering examples:</b>	
● Ex i	. . . . . /000-006	Terminal strip without fixing flanges, 10 mm pin spacing, 8-pole, Ex e II:	<b>745-1358/000-009/999-950</b>
		Terminal strip with fixing flanges, 10 mm pin spacing, 8-pole, Ex e II:	<b>745-1358/005-009/999-950</b>

Item no. suffixes for colored terminal strips: (Production and prices depend on quantity required)

● black	. . . . . /000-004	<b>Ordering examples:</b>	
● blue	. . . . . /000-006	Terminal strip without fixing flanges, 10 mm pin spacing, 8-pole, light gray:	<b>745-1358/000-009 (. . . . . /000- . . . without fixing flanges)</b>
○ light gray	. . . . . /000-009		
● green-yellow	. . . . . /000-016	with fixing flanges, 10 mm pin spacing, 8-pole, light gray:	<b>745-1358/005-009 (. . . . . /005- . . . with fixing flanges)</b>
● light green	. . . . . /000-017		
● green	. . . . . /000-023		



# PCB Terminal Strips with Jumper Slots 6 mm<sup>2</sup> Pin Spacing 7.5 mm, 10 mm 745 Series

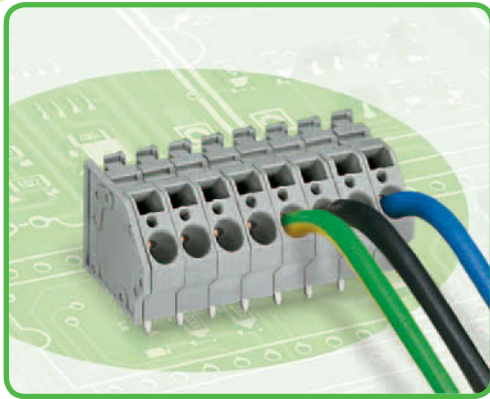

- Terminal strips with screwdriver-actuated CAGE CLAMP®
- versions with Ex e (increased safety) approval
- Comb-style jumper bars for looping through and distributing potentials
- Custom color combinations
- double solder pins for high mechanical stability
- Integrated test ports
- Marker slot for miniature WSB and WMB markers

### Technical data:

Pin Spacing	7.5 mm 0.295 in			10 mm 0.394 in		
Rating per	IEC/EN 60664-1			IEC/EN 60664-1		
Overtoltage category	III	III	II	III	III	II
Pollution degree	3	2	2	3	2	2
Rated voltage*	500 V	630 V	1000 V	630 V	1000 V	1000 V
Rated surge voltage	6 kV	6 kV	6 kV	8 kV	8 kV	8 kV
Nominal current	41 A	41 A	41 A	41 A	41 A	41 A
Approvals per	UL/CSA			UL/CSA		
Use group UL1059	B	C	D	B	C	D
Rated voltage	300 V	150 V	300 V	300 V	150 V	300 V
Nominal current UL	30 A	30 A	10 A	30 A	30 A	10 A
Nominal current CSA	30 A	30 A	10 A	30 A	30 A	10 A

### Conductor and solder pin data:

Connection technology	CAGE CLAMP®
Conductor size: solid	0.2 - 6 mm <sup>2</sup>
Conductor size: fine-stranded	0.2 - 6 mm <sup>2</sup>
Conductor size: fine-stranded	0.25 - 4 mm <sup>2</sup> (with insulated ferrule)
Conductor size: fine-stranded	0.25 - 4 mm <sup>2</sup> (with uninsulated ferrule)
AWG	24 - 10
Strip length	11 - 12 mm / 0.43 - 0.47 in
Conductor entry angle	45° to PCB
Solder pin: length/width	4.5 mm / 1 x 1.4 mm
Solder pin: drilled hole diameter	1.8 <sup>+0.1</sup> mm

### Material data:

Material group	I
Insulating material	Nylon 6.6 (PA 6.6)
Flammability rating per UL 94	V0
Lower/Upper temperature limit	-60°C / +105°C
Clamping spring material	Chrome-nickel spring steel (CrNi)
Contact material	Electrolytic copper (E <sub>Cu</sub> )
Contact plating	tin-plated

### Technical data for Ex e II () versions:

Pin Spacing	7.5 mm 0.295 in	10 mm 0.394 in
Rating per	ATEX: PTB 06 ATEX 1014 U IECEx: IECEx PTB 06.0039 U	
Rated voltage	275 V	440 V
Nominal current without jumpers	37 A	37 A
Nominal current with jumpers	31 A	31 A

\* Using adjacent jumpers, the rated voltage is reduced to 400 V with pin spacing of 7.5 mm in Category III/3.

### Note on UL approval for 600 V:

The conductor entry is for field and factory wiring and meets spacing requirements for 600 V UL (Use Group: C). The solder pins are for factory wiring only. The suitability and spacing shall be evaluated in the end-use equipment, based on relevant end-product standard.

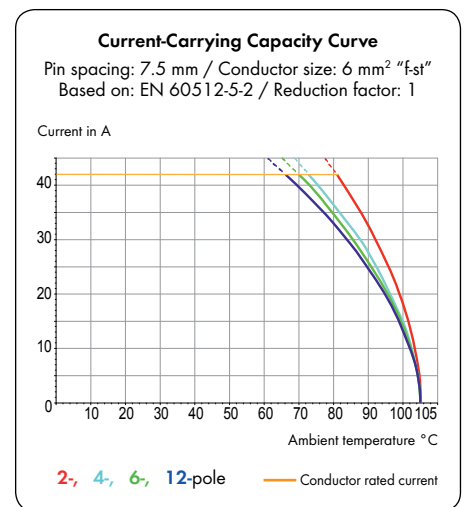

### 745 Series accessories:

### Page:

Marking accessories	540 - 543
Operating tools	526 - 528
Comb-style jumper bars	197
Test plugs	538

Pin spacing 7.5 mm / 0.295 in		Pin spacing 10 mm / 0.394 in	
0.2 – 6 mm <sup>2</sup>	AWG 24 – 10	0.2 – 6 mm <sup>2</sup>	AWG 24 – 10
630 V/6 kV/2 41 A	300 V/10 A	1000 V/8 kV/2 41 A	300 V/10 A

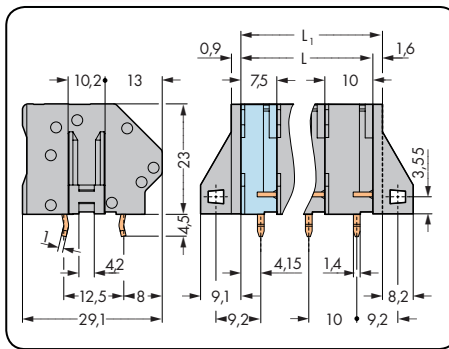
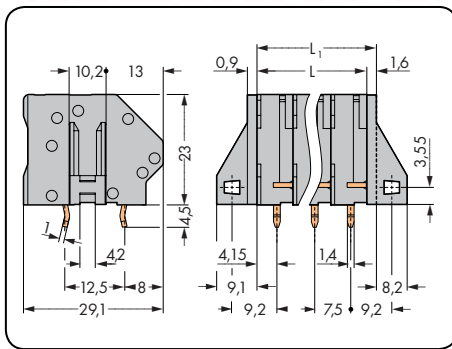
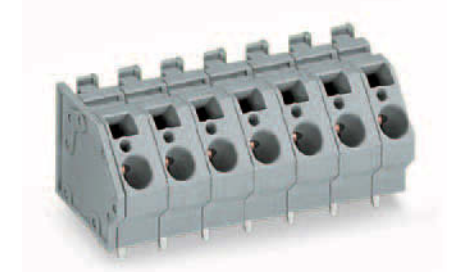

L = (pole no. - 1) x pin spacing + 7.5 mm  
 L<sub>1</sub> = L + 1.6 mm  $\Delta$  without fixing flanges

Pole No.	Item No.	Pack. Unit	Pole No.	Item No.	Pack. Unit
Terminal strip with jumper slot, 2 solder pins/pole, gray			Terminal strip with jumper slot, 2 solder pins/pole, gray		
2	745-302	128	2	745-352	104
3	745-303	88	3	745-353	72
4	745-304	64	4	745-354	48
5	745-305	48	5	745-355	40
6	745-306	40	6	745-356	32
7	745-307	40	7	745-357	24
8	745-308	32	8	745-358	24
9	745-309	24	9	745-359	24
10	745-310	24	10	745-360	16
12	745-312	16	12	745-362	16

Item no. suffix for terminal strips with fixing flanges: . . . . . /005-000

Item no. suffixes for Ex e II and Ex i applications:

○ Ex e II	. . . . . /000-009/999-950	<b>Ordering examples:</b>
● Ex i	. . . . . /000-006	Terminal strip without fixing flanges, 10 mm pin spacing, 8-pole, Ex e II: <b>745-358/000-009/999-950</b>
		Terminal strip with fixing flanges, 10 mm pin spacing, 8-pole, Ex e II: <b>745-358/005-009/999-950</b>

Item no. suffixes for colored terminal strips: (Production and prices depend on quantity required)

● black	. . . . . /000-004	<b>Ordering examples:</b>
● blue	. . . . . /000-006	Terminal strip without fixing flanges, 10 mm pin spacing, 8-pole, light gray: <b>745-308/000-009 (. . . . . /000- . . . without fixing flanges)</b>
○ light gray	. . . . . /000-009	
● green-yellow	. . . . . /000-016	
● light green	. . . . . /000-017	with fixing flanges, 10 mm pin spacing, 8-pole, light gray: <b>745-308/005-009 (. . . . . /005- . . . with fixing flanges)</b>
● green	. . . . . /000-023	

# Modular PCB Terminal Blocks with Jumper Slots 16 mm<sup>2</sup> Pin Spacing 10 mm, 15 mm, 20 mm 745 Series

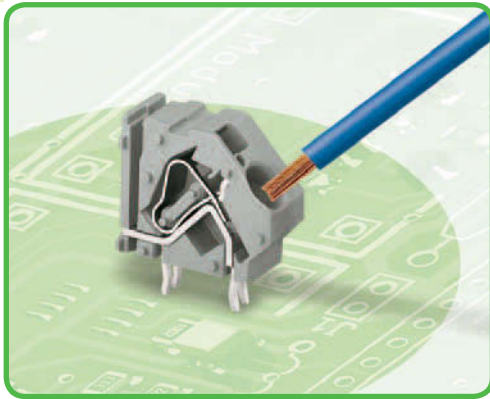

- Modular terminal blocks with screwdriver-actuated CAGE CLAMP® for custom terminal strip assemblies
- versions with Ex e (increased safety) approval
- UL approval up to 600 V for 20 mm pin spacing
- Comb-style jumper bars for commoning and distributing potentials
- Four solder pins for high mechanical stability
- Integrated test port
- Marker slot for miniature WSB and WMB markers

**Technical data:**

Pin Spacing	10 mm 0.394 in			15 mm 0.591 in			20 mm 0.787 in		
Rating per	IEC/EN 60664-1			IEC/EN 60664-1			IEC/EN 60664-1		
Overtoltage category	III	III	II	III	III	II	III	III	II
Pollution degree	3	2	2	3	2	2	3	2	2
Rated voltage	320 V	320 V	630 V	630 V	1000 V	1000 V	1000 V	1000 V	1000 V
Rated surge voltage	4 kV	4 kV	4 kV	8 kV	8 kV	8 kV	12 kV	12 kV	12 kV
Nominal current	76 A	76 A	76 A	76 A	76 A	76 A	76 A	76 A	76 A
Approvals per	UL/CSA			UL/CSA			UL/CSA		
Use group UL 1059	B	C	D	B	C	D	B	C	D
Rated voltage	300 V	-	300 V	300 V	300 V	600 V	600 V	600 V	-
Nominal current UL	10 A	-	10 A	65 A	65 A	5 A	65 A	65 A	-
Nominal current CSA	10 A	-	10 A	65 A	65 A	5 A	65 A	65 A	-

**Conductor and solder pin data:**

Connection technology	CAGE CLAMP®
Conductor size: solid	0.2 - 16 mm <sup>2</sup>
Conductor size: fine-stranded	0.2 - 16 mm <sup>2</sup>
Conductor size: fine-stranded	0.25 - 10 mm <sup>2</sup> (with insulated ferrule)
Conductor size: fine-stranded	0.25 - 10 mm <sup>2</sup> (with uninsulated ferrule)
AWG	24 - 6
Strip length	12 - 13 mm / 0.47 - 0.51 in
Conductor entry angle	45° to PCB
Solder pin: length/width	6.5 (5) mm / 1.2 x 1.6 mm
Solder pin: drilled hole diameter	2.2 <sup>+0.1</sup> mm

**Material data:**

Material group	I
Insulation material	Nylon 6.6 (PA 6.6)
Flammability rating per UL 94	V0
Lower/Upper temperature limit	-60°C / +105°C
Clamping spring material	Chrome-nickel spring steel (CrNi)
Contact material	Electrolytic copper (E <sub>Cu</sub> )
Contact plating	tin-plated

**Technical data for Ex e II ( ) versions:**

Pin Spacing	10 mm 0.394 in	15 mm 0.591 in	20 mm 0.787 in
Rating per	ATEX: PTB 06 ATEX 1014 U IECEx: IECEx PTB 06.0039 U		
Rated voltage	220 V	440 V	690 V
Nominal current without jumpers	71 A	71 A	71 A
Nominal current with jumpers	53 A	53 A	53 A

**Note on UL approval for 600 V:**

The conductor entry is for field and factory wiring and meets spacing requirements for 600 V UL (Use Group: C). The solder pins are for factory wiring only. The suitability and spacing shall be evaluated in the end-use equipment, based on relevant end-product standard.

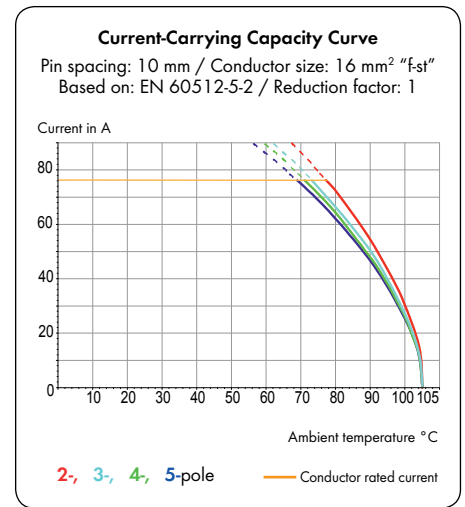

**745 Series accessories:**

**Page:**

Marking accessories	540 - 543
Operating tools	526 - 528
Comb-style jumper bars	197
Test plugs	538

Pin spacing 10 mm / 0.394 in		Pin spacing 15 mm / 0.591 in		Pin spacing 20 mm / 0.787 in	
0.2 – 16 mm <sup>2</sup>	AWG 24 – 6	0.2 – 16 mm <sup>2</sup>	AWG 24 – 6	0.2 – 16 mm <sup>2</sup>	AWG 24 – 6
320 V/4 kV/2 76 A	300 V/10 A	1000 V/8 kV/2 76 A	300 V/65 A	1000 V/12 kV/2 76 A	600 V/65 A

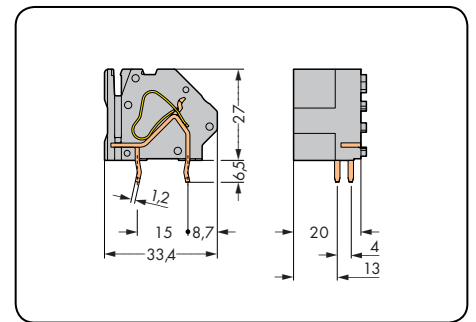
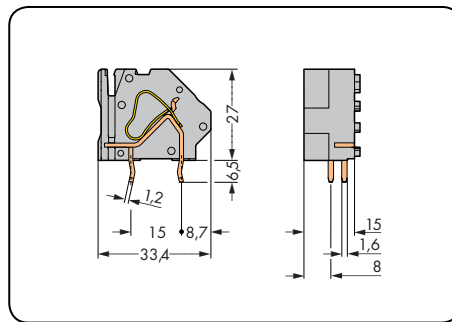
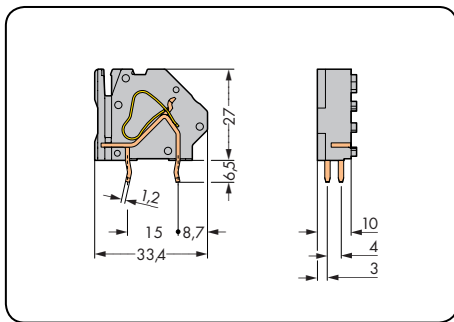

Color	Order No.	Pack. Unit	Color	Item No.	Pack. Unit	Color	Item No.	Pack. Unit
<b>Modular terminal block with jumper slot, 4 solder pins/pole</b>			<b>Modular terminal block with jumper slot, 4 solder pins/pole</b>			<b>Modular terminal block with jumper slot, 4 solder pins/pole</b>		
● gray	745-851/006-000	100	● gray	745-871/006-000	100	● gray	745-881/006-000	50
● light gray	745-853/006-000	100	● light gray	745-873/006-000	100	● light gray	745-883/006-000	50
① blue	745-854/006-000	100	① blue	745-874/006-000	100	① blue	745-884/006-000	50
● green-yellow	745-857/006-000	100	● green-yellow	745-877/006-000	100	● green-yellow	745-887/006-000	50
● light green	745-858/006-000	100	● light green	745-878/006-000	100	● light green	745-888/006-000	50
○ Ex e II	745-853/006-000/999-950		○ Ex e II	745-873/006-000/999-950		○ Ex e II	745-883/006-000/999-950	
① Suitable for Ex i applications			① Suitable for Ex i applications			① Suitable for Ex i applications		
<b>Item no. suffix for modular terminal blocks with 5 mm long solder pins:</b>			... .. /007-000					

End plates, 745 Series – 16 mm <sup>2</sup>	Item No.	Pack. Unit
	745-500	500 (10 x 50)
	745-540	200 (4 x 50)
	745-545	200 (4 x 50)
<b>Item no. suffixes for end plates in different colors:</b>		
● blue	... .. /000-006	<b>Ordering example:</b>
● light gray	... .. /000-009	End plate with fixing flange,
● green-yellow	... .. /000-016	light gray: 745-540/000-009
● light green	... .. /000-017	

# PCB Terminal Strips with Jumper Slots 16 mm<sup>2</sup> Pin Spacing 10 mm, 15 mm, 20 mm 745 Series

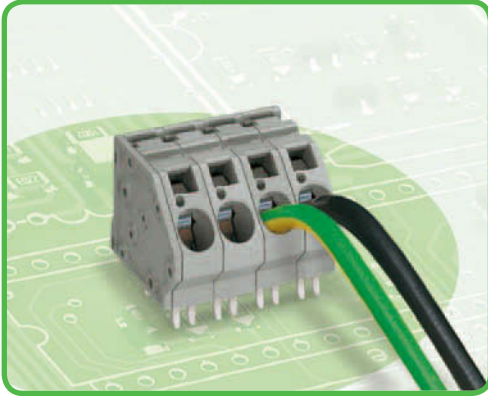

- Terminal strips with screwdriver-actuated CAGE CLAMP®
- versions with Ex e (increased safety) approval
- UL approval up to 600 V for 20 mm pin spacing
- Comb-style jumper bars for commoning and distributing potentials
- Four solder pins for high mechanical stability
- Integrated test ports
- Marker slot for miniature WSB and WMB markers

**Technical data:**

Pin Spacing	10 mm 0.394 in			15 mm 0.591 in			20 mm 0.787 in		
	IEC/EN 60664-1			IEC/EN 60664-1			IEC/EN 60664-1		
Rating per	III	III	II	III	III	II	III	III	II
Overtoltage category	3	2	2	3	2	2	3	2	2
Pollution degree	3	2	2	3	2	2	3	2	2
Rated voltage	320 V	320 V	630 V	630 V	1000 V	1000 V	1000 V	1000 V	1000 V
Rated surge voltage	4 kV	4 kV	4 kV	8 kV	8 kV	8 kV	12 kV	12 kV	12 kV
Nominal current	76 A	76 A	76 A	76 A	76 A	76 A	76 A	76 A	76 A
Approvals per	UL/CSA			UL/CSA			UL/CSA		
Use group UL 1059	B	C	D	B	C	D	B	C	D
Rated voltage	300 V	-	300 V	300 V	300 V	600 V	600 V	600 V	-
Nominal current UL	10 A	-	10 A	65 A	65 A	5 A	65 A	65 A	-
Nominal current CSA	10 A	-	10 A	65 A	65 A	5 A	65 A	65 A	-

**Conductor and solder pin data:**

Connection technology	CAGE CLAMP®
Conductor size: solid	0.2 - 16 mm <sup>2</sup>
Conductor size: fine-stranded	0.2 - 16 mm <sup>2</sup>
Conductor size: fine-stranded	0.25 - 10 mm <sup>2</sup> (with insulated ferrule)
Conductor size: fine-stranded	0.25 - 10 mm <sup>2</sup> (with uninsulated ferrule)
AWG	24 - 6
Strip length	12 - 13 mm / 0.47 - 0.51 in
Conductor entry angle	45° to PCB
Solder pin: length/width	6.5 (5) mm / 1.2 x 1.6 mm
Solder pin: drilled hole diameter	2.2 <sup>+0.1</sup> mm

**Material data:**

Material group	I
Insulation material	Nylon 6.6 (PA 6.6)
Flammability rating per UL 94	V0
Lower/Upper temperature limit	-60°C / +105°C
Clamping spring material	Chrome-nickel spring steel (CrNi)
Contact material	Electrolytic copper (E <sub>Cu</sub> )
Contact plating	tin-plated

**Technical data for Ex e II ( ) versions:**

Pin Spacing	10 mm 0.394 in	15 mm 0.591 in	20 mm 0.787 in
Rating per	ATEX: PTB 06 ATEX 1014 U IECEx: IECEx PTB 06.0039 U		
Rated voltage	220 V	440 V	690 V
Nominal current without jumpers	71 A	71 A	71 A
Nominal current with jumpers	53 A	53 A	53 A

**Note on UL approval for 600 V:**

The conductor entry is for field and factory wiring and meets spacing requirements for 600 V UL (Use Group: C). The solder pins are for factory wiring only. The suitability and spacing shall be evaluated in the end-use equipment, based on relevant end-product standard.

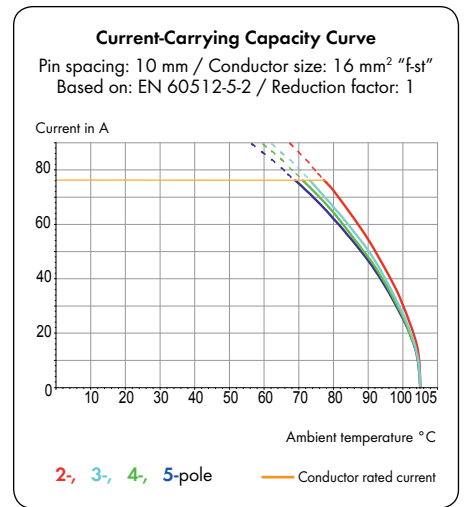

**745 Series accessories:**

**Page:**

Marking accessories	540 - 543
Operating tools	526 - 528
Comb-style jumper bars	197
Test plugs	538



# PCB Terminal Strips with Jumper Slots 16 mm<sup>2</sup>

CAGE CLAMP®

Pin spacing 10 mm / 0.394 in		Pin spacing 15 mm / 0.591 in		Pin spacing 20 mm / 0.787 in	
0.2 - 16 mm <sup>2</sup>	AWG 24 - 6	0.2 - 16 mm <sup>2</sup>	AWG 24 - 6	0.2 - 16 mm <sup>2</sup>	AWG 24 - 6
320 V/4 kV/2 76 A	300 V/10 A	1000 V/8 kV/2 76 A	300 V/65 A	1000 V/12 kV/2 76 A	600 V/65 A

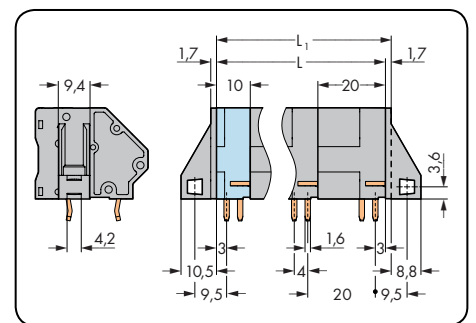
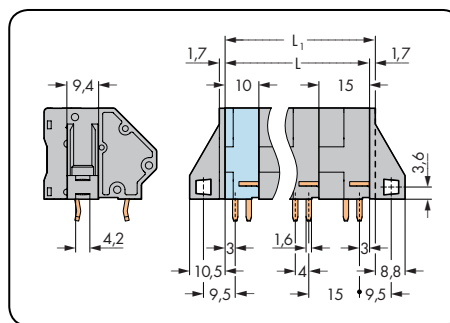
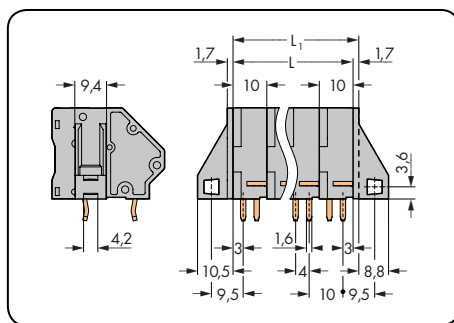

$L = (\text{pole no.} - 1) \times \text{pin spacing} + 10 \text{ mm}$   
 $L_1 = L + 1.7 \text{ mm} \triangleq \text{without fixing flanges}$

Pole No.	Item No.	Pack. Unit	Pole No.	Item No.	Pack. Unit	Pole No.	Item No.	Pack. Unit
<b>Terminal strip with jumper slot, 4 solder pins/pole, gray</b>			<b>Terminal strip with jumper slot, 4 solder pins/pole, gray</b>			<b>Terminal strip with jumper slot, 4 solder pins/pole, gray</b>		
2	745-502/006-000	48	2	745-602/006-000	36	2	745-652/006-000	32
3	745-503/006-000	32	3	745-603/006-000	24	3	745-653/006-000	20
4	745-504/006-000	24	4	745-604/006-000	16	4	745-654/006-000	12
5	745-505/006-000	20	5	745-605/006-000	12	5	745-655/006-000	8
Item no. suffix for terminal strips with fixing flanges:			. . . . . /011-000					
Item no. suffix for terminal strips with 5 mm long solder pins:			. . . . . /007-000					

Item no. suffixes for Ex e II and Ex i applications:

○ Ex e II	. . . . . /000-009/999-950	<b>Ordering examples:</b>
● Ex i	. . . . . /000-006	Terminal strip without fixing flange, 10 mm pin spacing, 5-pole, Ex e II: <b>745-505/006-009/999-950</b>
		Terminal strip with fixing flanges, 10 mm pin spacing, 5-pole, Ex e II: <b>745-505/011-009/999-950</b>

Item no. suffixes for colored terminal strips: (Production and prices depend on quantity required)

● black	. . . . . /000-004	<b>Ordering examples:</b>
● blue	. . . . . /000-006	Terminal strip without fixing flange, 20 mm pin spacing, 5-pole, light gray: <b>745-655/006-009 (. . . . . /006- . . . without fixing flanges)</b>
○ light gray	. . . . . /000-009	
● green-yellow	. . . . . /000-016	
● light green	. . . . . /000-017	Terminal strip with fixing flanges, 20 mm pin spacing, 5-pole, light gray: <b>745-655/011-009 (. . . . . /011- . . . with fixing flanges)</b>
● green	. . . . . /000-023	

# Double-Deck PCB Terminal Strips 2.5 mm<sup>2</sup> Pin Spacing 5 mm, 7.5 mm, 10 mm 736 Series

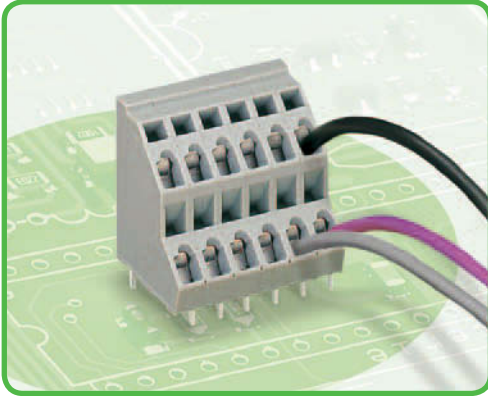

- Terminal strips with screwdriver-actuated CAGE CLAMP®
- High-density, double-deck design for space-efficient wiring of multiple conductors in confined areas
- Custom direct marking for all termination levels
- Terminal strips with commoning strips for distributing potentials, see pages 67 – 69

**Technical data:**

Pin Spacing	5 mm 0.179 in			7.5 mm 0.295 in			10 mm 0.394 in		
	IEC/EN 60664-1			IEC/EN 60664-1			IEC/EN 60664-1		
Rating per	IEC/EN 60664-1			IEC/EN 60664-1			IEC/EN 60664-1		
Overvoltage category	III	III	II	III	III	II	III	III	II
Pollution degree	3	2	2	3	2	2	3	2	2
Rated voltage	250 V	320 V	630 V	400 V	630 V	1000 V	630 V	1000 V	1000 V
Rated surge voltage	4 kV	4 kV	4 kV	6 kV	6 kV	6 kV	8 kV	8 kV	8 kV
Nominal current	21 A	21 A	21 A	21 A	21 A	21 A	21 A	21 A	21 A
Approvals per	UL/CSA			UL/CSA			UL/CSA		
Use group UL 1059	B	C	D	B	C	D	B	C	D
Rated voltage	300 V	-	300 V	300 V	-	300 V	300 V	-	300 V
Nominal current UL	10 A	-	10 A	10 A	-	10 A	10 A	-	10 A
Nominal current CSA	10 A	-	10 A	10 A	-	10 A	10 A	-	10 A

**Conductor and solder pin data:**

Connection technology	CAGE CLAMP®
Conductor size: solid	0.08 – 2.5 mm <sup>2</sup>
Conductor size: fine-stranded	0.08 – 2.5 mm <sup>2</sup>
Conductor size: fine-stranded	0.25 – 1.5 mm <sup>2</sup> (with insulated ferrule)
Conductor size: fine-stranded	0.25 – 2.5 mm <sup>2</sup> (with uninsulated ferrule)
AWG	28 – 12 (12: THHN, THWN)
Strip length	5 – 6 mm / 0.20 – 0.24 in
Conductor entry angle	45° to PCB
Solder pin: length/width	4 mm / 0.7 x 0.7 mm
Solder pin: drilled hole diameter	1.3 <sup>+0.1</sup> mm

**Material data:**

Material group	I
Insulation material	Nylon 6.6 (PA 6.6)
Flammability rating per UL 94	V0
Lower/Upper temperature limit	-60°C / +105°C
Clamping spring material	Chrome-nickel spring steel (CrNi)
Contact material	Electrolytic copper (E <sub>Cu</sub> )
Contact plating	tin-plated

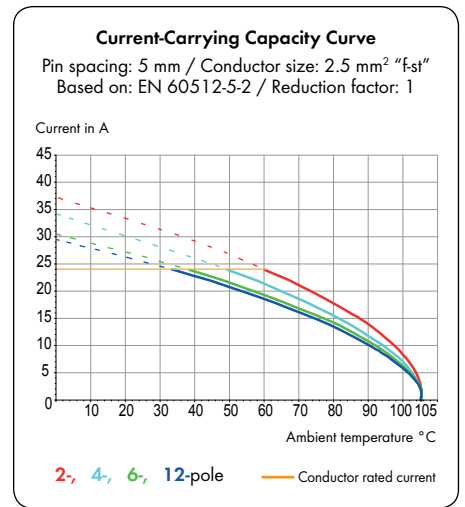

**736 Series accessories:**

**Page:**

Marking accessories	540 – 543
Operating tools	526 – 528
Commoning strips	67 – 69
Test plug modules	198 – 199

# Double-Deck PCB Terminal Strips 2.5 mm<sup>2</sup>

CAGE CLAMP®

1  
47

1

Solder pins in line Pin spacing 5 mm / 0.197 in		Solder pins staggered Pin spacing 5 mm / 0.197 in	
0.08 - 2.5 mm <sup>2</sup>	AWG 28 - 12	0.08 - 2.5 mm <sup>2</sup>	AWG 28 - 12
320 V/4 kV/2 21 A	300 V/10 A	320 V/4 kV/2 21 A	300 V/10 A

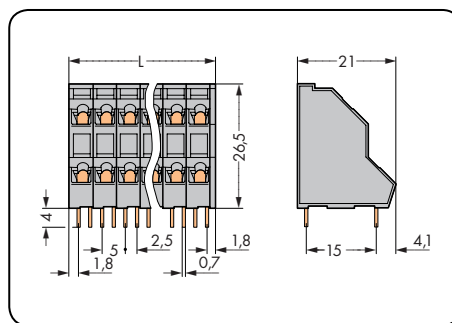
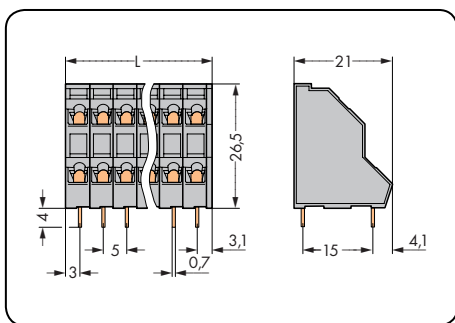

$L = (\text{pole no.} \times \text{pin spacing}) + 1 \text{ mm}$

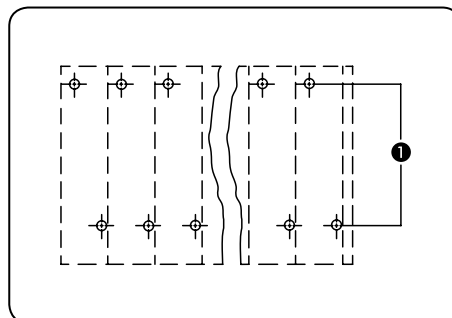
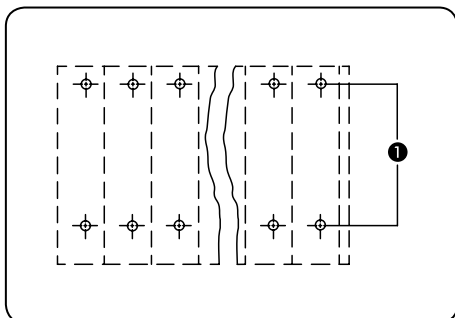

Solder pins in line

Solder pins staggered by half the pin spacing

- ① Voltage rating between adjacent poles:  
 320 V/4 kV/3 (III)  
 320 V/4 kV/2 (III)  
 630 V/4 kV/2 (II)

Pole No.	Item No.	Pack. Unit	Pole No.	Item No.	Pack. Unit
Double-deck terminal strip, 2 solder pins in line, gray			Double-deck terminal strip, 2 solder pins staggered by half the pin spacing, gray		
2 x 2	736-102	161	2 x 2	736-202	161
3 x 2	736-103	112	3 x 2	736-203	112
4 x 2	736-104	84	4 x 2	736-204	84
6 x 2	736-106	56	6 x 2	736-206	56
8 x 2	736-108	42	8 x 2	736-208	42
12 x 2	736-112	28	12 x 2	736-212	28
16 x 2	736-116	21	16 x 2	736-216	21
24 x 2	736-124	14	24 x 2	736-224	14

# Double-Deck PCB Terminal Strips 2.5 mm<sup>2</sup> 736 Series

Solder pins in line Pin spacing 7.5 mm / 0.295 in		Solder pins staggered Pin spacing 7.5 mm / 0.295 in	
0.08 - 2.5 mm <sup>2</sup>	AWG 28 - 12	0.08 - 2.5 mm <sup>2</sup>	AWG 28 - 12
630 V/6 kV/2 21 A	300 V/10 A	630 V/6 kV/2 21 A	300 V/10 A

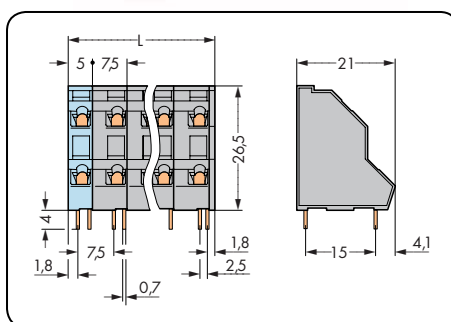
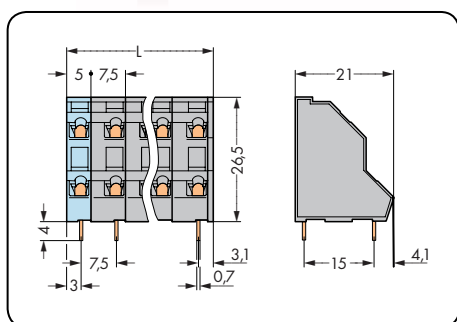
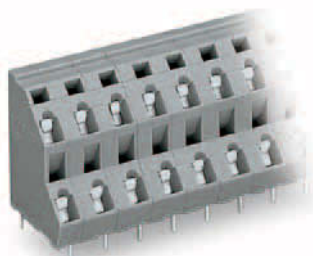
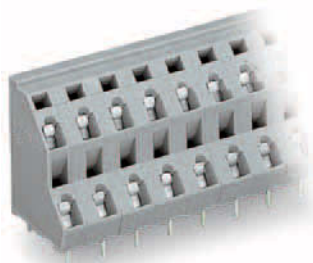

$L = (\text{pole no.} - 1) \times \text{pin spacing} + 5 \text{ mm} + 1 \text{ mm}$

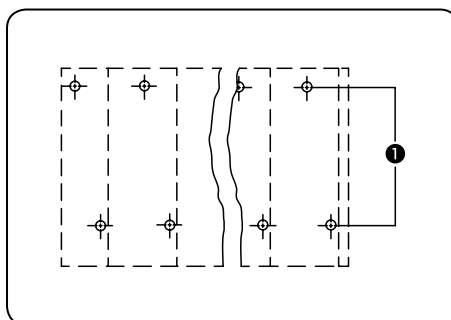
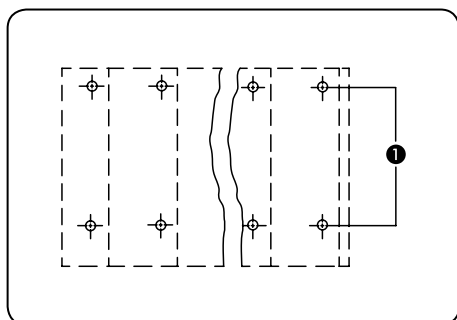

Solder pins in line

Solder pins staggered by half the pin spacing

- ❶ Voltage rating between adjacent poles:  
320 V/4 kV/3 (III)  
320 V/4 kV/2 (III)  
630 V/4 kV/2 (II)

Pole No.	Item No.	Pack. Unit	Pole No.	Item No.	Pack. Unit
Double-deck terminal strip, 2 solder pins in line, gray			Double-deck terminal strip, 2 solder pins staggered by half the pin spacing, gray		
2 x 2	736-502	133	2 x 2	736-552	133
3 x 2	736-503	84	3 x 2	736-553	84
4 x 2	736-504	63	4 x 2	736-554	63
6 x 2	736-506	42	6 x 2	736-556	42
8 x 2	736-508	28	8 x 2	736-558	28
12 x 2	736-512	21	12 x 2	736-562	21
16 x 2	736-516	14	16 x 2	736-566	14

# Double-Deck PCB Terminal Strips 2.5 mm<sup>2</sup>

CAGE CLAMP®

Solder pins in line Pin spacing 10 mm / 0.394 in		Solder pins staggered Pin spacing 10 mm / 0.394 in	
0.08 - 2.5 mm <sup>2</sup>	AWG 28 - 12	0.08 - 2.5 mm <sup>2</sup>	AWG 28 - 12
1000 V/8 kV/2 21 A	300 V/10 A	1000 V/8 kV/2 21 A	300 V/10 A

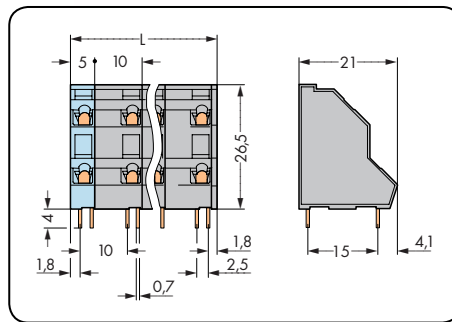
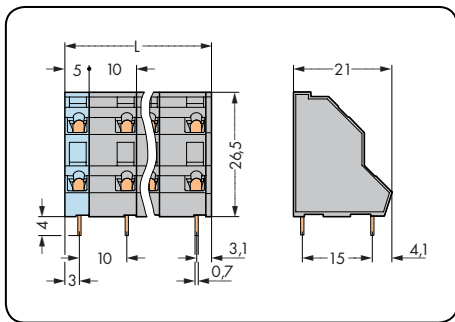
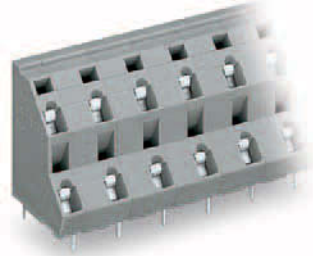
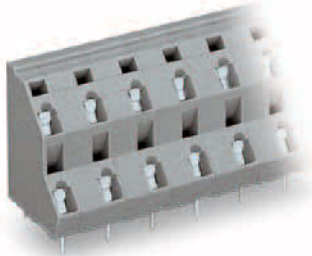

$L = (\text{pole no.} - 1) \times \text{pin spacing} + 5 \text{ mm} + 1 \text{ mm}$

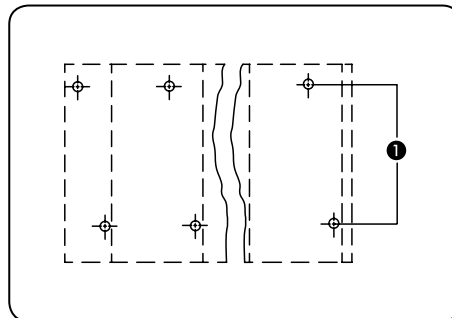
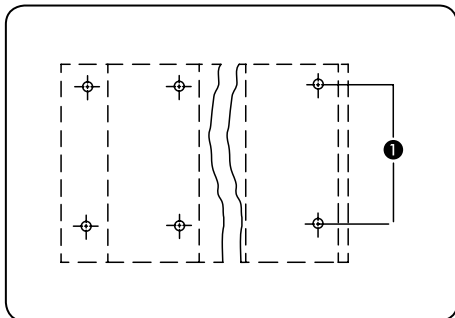

Solder pins in line

Solder pins staggered by half the pin spacing

- ① Voltage rating between adjacent poles:  
 320 V/4 kV/3 (III)  
 320 V/4 kV/2 (III)  
 630 V/4 kV/2 (II)

Pole No.	Item No.	Pack. Unit	Pole No.	Item No.	Pack. Unit
Double-deck terminal strip, 2 solder pins in line, gray			Double-deck terminal strip, 2 solder pins staggered by half the pin spacing, gray		
2 x 2	736-702	112	2 x 2	736-752	112
3 x 2	736-703	70	3 x 2	736-753	70
4 x 2	736-704	49	4 x 2	736-754	49
6 x 2	736-706	28	6 x 2	736-756	28
8 x 2	736-708	21	8 x 2	736-758	21
12 x 2	736-712	14	12 x 2	736-762	14



# Double-Deck PCB Terminal Strips 2.5 mm<sup>2</sup> Pin Spacing 5.08 mm, 7.62 mm, 10.16 mm 736 Series

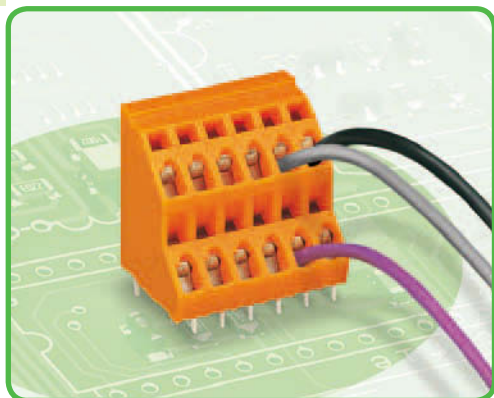

- Terminal strips with screwdriver-actuated CAGE CLAMP®
- High-density, double-deck design for space-efficient wiring of multiple conductors in confined areas
- Custom direct marking for all termination levels
- Terminal strips with commoning strips for distributing potentials, see pages 67 – 69

### Technical data:

Pin Spacing	5.08 mm 0.2 in			7.62 mm 0.3 in			10.16 mm 0.4 in		
	IEC/EN 60664-1			IEC/EN 60664-1			IEC/EN 60664-1		
Rating per									
Overvoltage category	III	III	II	III	III	II	III	III	II
Pollution degree	3	2	2	3	2	2	3	2	2
Rated voltage	250 V	320 V	630 V	400 V	630 V	1000 V	630 V	1000 V	1000 V
Rated surge voltage	4 kV	4 kV	4 kV	6 kV	6 kV	6 kV	8 kV	8 kV	8 kV
Nominal current	21 A	21 A	21 A	21 A	21 A	21 A	21 A	21 A	21 A
Approvals per	UL/CSA			UL/CSA			UL/CSA		
Use group UL 1059	B	C	D	B	C	D	B	C	D
Rated voltage	300 V	-	300 V	300 V	-	300 V	300 V	-	300 V
Nominal current UL	10 A	-	10 A	10 A	-	10 A	10 A	-	10 A
Nominal current CSA	10 A	-	10 A	10 A	-	10 A	10 A	-	10 A

### Conductor and solder pin data:

Connection technology	CAGE CLAMP®
Conductor size: solid	0.08 – 2.5 mm <sup>2</sup>
Conductor size: fine-stranded	0.08 – 2.5 mm <sup>2</sup>
Conductor size: fine-stranded	0.25 – 1.5 mm <sup>2</sup> (with insulated ferrule)
Conductor size: fine-stranded	0.25 – 2.5 mm <sup>2</sup> (with uninsulated ferrule)
AWG	28 – 12 (12: THHN, THWN)
Strip length	5 – 6 mm / 0.20 – 0.24 in
Conductor entry angle	45° to PCB
Solder pin: length/width	4 mm / 0.7 x 0.7 mm
Solder pin: drilled hole diameter	1.3 <sup>+0.1</sup> mm

### Material data:

Material group	I
Insulation material	Nylon 6.6 (PA 6.6)
Flammability rating per UL 94	V0
Lower/Upper temperature limit	-60°C / +105°C
Clamping spring material	Chrome-nickel spring steel (CrNi)
Contact material	Electrolytic copper (E <sub>Cu</sub> )
Contact plating	tin-plated

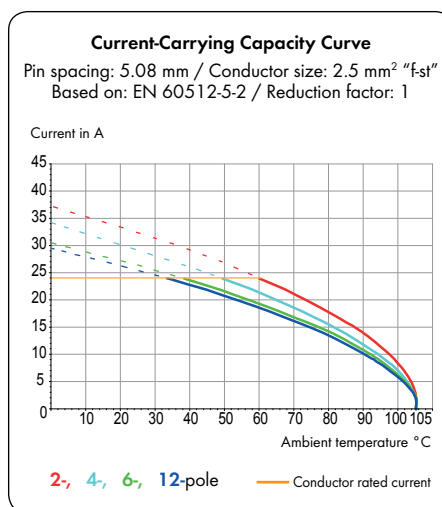

### 736 Series accessories:

### Page:

Marking accessories	540 – 543
Operating tools	526 – 528
Commoning strips	67 – 69
Test plug modules	198 – 199

# Double-Deck PCB Terminal Strips 2.5 mm<sup>2</sup>

CAGE CLAMP®

Solder pins in line Pin spacing 5.08 mm / 0.2 in		Solder pins staggered Pin spacing 5.08 mm / 0.2 in	
0.08 - 2.5 mm <sup>2</sup>	AWG 28 - 12	0.08 - 2.5 mm <sup>2</sup>	AWG 28 - 12
320 V/4 kV/2 21 A	300 V/10 A	320 V/4 kV/2 21 A	300 V/10 A

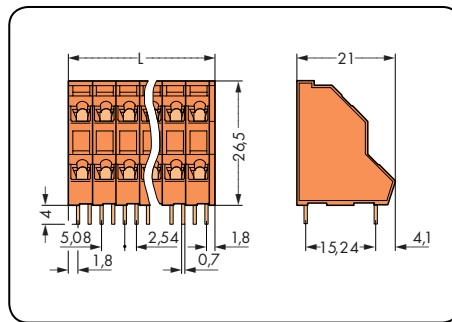
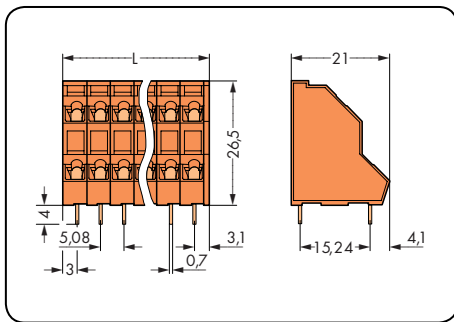
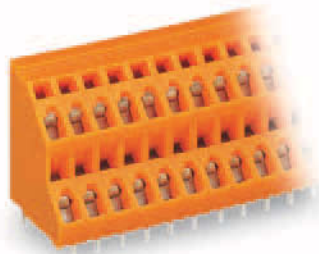
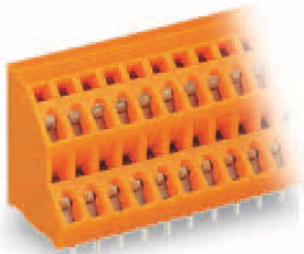

L = (pole no. x pin spacing) + 1 mm

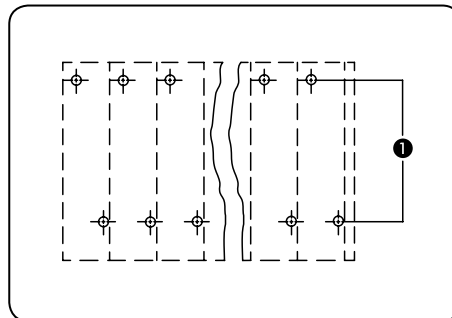
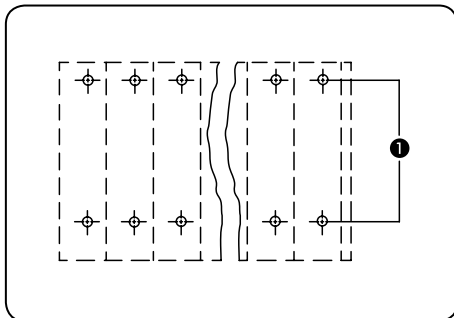

Solder pins in line

Solder pins staggered by half the pin spacing

- ❶ Voltage rating between adjacent poles:  
320 V/4 kV/3 (III)  
320 V/4 kV/2 (III)  
630 V/4 kV/2 (II)

Pole No.	Item No.	Pack. Unit	Pole No.	Item No.	Pack. Unit
Double-deck terminal strip, 2 solder pins in line, orange			Double-deck terminal strip, 2 solder pins staggered by half the pin spacing, orange		
2 x 2	736-302	161	2 x 2	736-402	161
3 x 2	736-303	112	3 x 2	736-403	112
4 x 2	736-304	84	4 x 2	736-404	84
6 x 2	736-306	56	6 x 2	736-406	56
8 x 2	736-308	42	8 x 2	736-408	42
12 x 2	736-312	28	12 x 2	736-412	28
16 x 2	736-316	21	16 x 2	736-416	21
24 x 2	736-324	14	24 x 2	736-424	14

# Double-Deck PCB Terminal Strips 2.5 mm<sup>2</sup> 736 Series

Solder pins in line Pin spacing 7.62 mm / 0.3 in		Solder pins staggered Pin spacing 7.62 mm / 0.3 in	
0.08 - 2.5 mm <sup>2</sup>	AWG 28 - 12	0.08 - 2.5 mm <sup>2</sup>	AWG 28 - 12
630 V/6 kV/2 21 A	300 V/10 A	630 V/6 kV/2 21 A	300 V/10 A

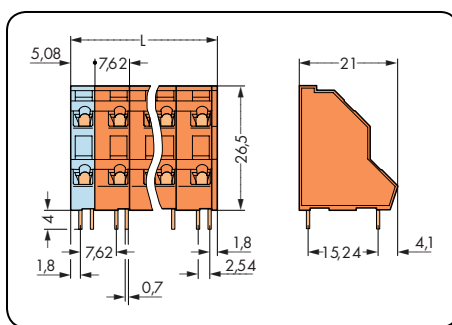
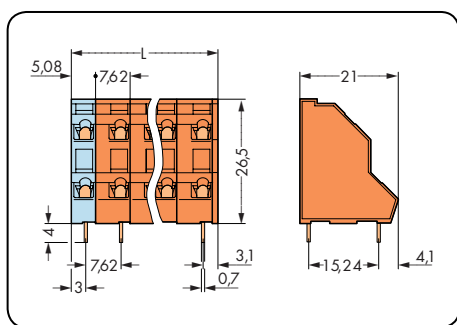
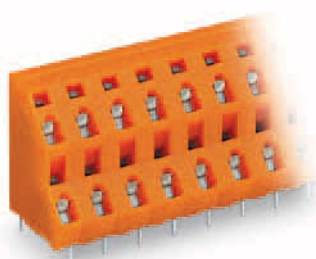
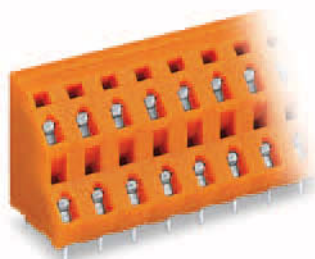

L = (pole no. - 1) x pin spacing + 5.08 mm + 1 mm

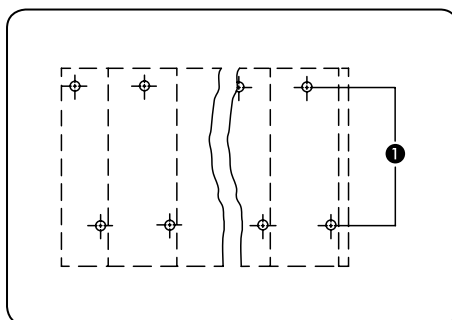
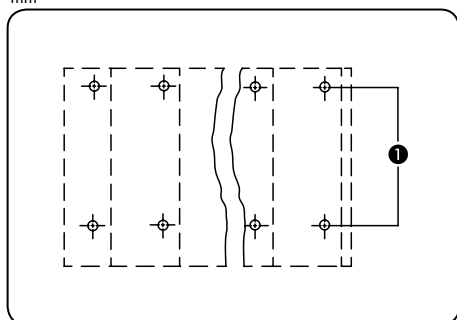

Solder pins in line

Solder pins staggered by half the pin spacing

- ❶ Voltage rating between adjacent poles:
  - 320 V/4 kV/3 (III)
  - 320 V/4 kV/2 (III)
  - 630 V/4 kV/2 (II)

Pole No.	Item No.	Pack. Unit	Pole No.	Item No.	Pack. Unit
Double-deck terminal strip, 2 solder pins in line, orange			Double-deck terminal strip, 2 solder pins staggered by half the pin spacing, orange		
2 x 2	736-602	133	2 x 2	736-652	133
3 x 2	736-603	84	3 x 2	736-653	84
4 x 2	736-604	63	4 x 2	736-654	63
6 x 2	736-606	35	6 x 2	736-656	35
8 x 2	736-608	28	8 x 2	736-658	28
12 x 2	736-612	14	12 x 2	736-662	14
16 x 2	736-616	14	16 x 2	736-666	14

# Double-Deck PCB Terminal Strips 2.5 mm<sup>2</sup>

Solder pins in line Pin spacing 10.16 mm / 0.4 in		Solder pins staggered Pin spacing 10.16 mm / 0.4 in	
0.08 - 2.5 mm <sup>2</sup>	AWG 28 - 12	0.08 - 2.5 mm <sup>2</sup>	AWG 28 - 12
1000 V/8 kV/2 21 A	300 V/10 A	1000 V/8 kV/2 21 A	300 V/10 A

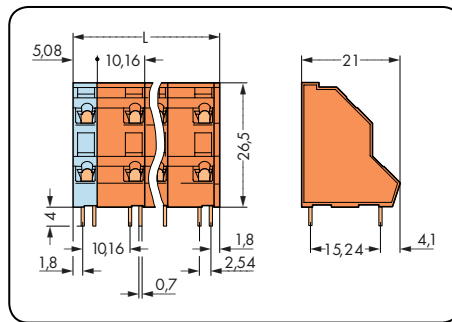
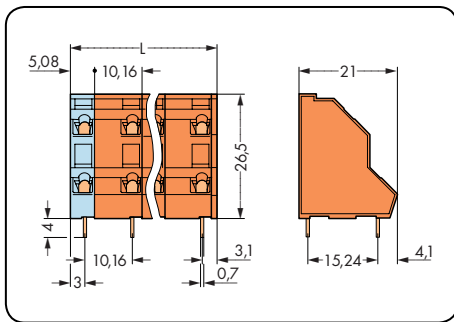
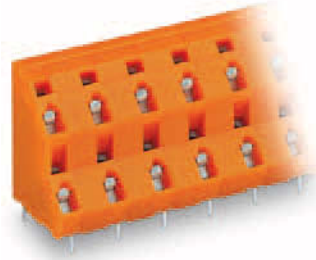
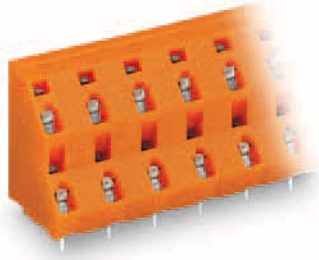

$L = (\text{pole no.} - 1) \times \text{pin spacing} + 5.08 \text{ mm} + 1 \text{ mm}$

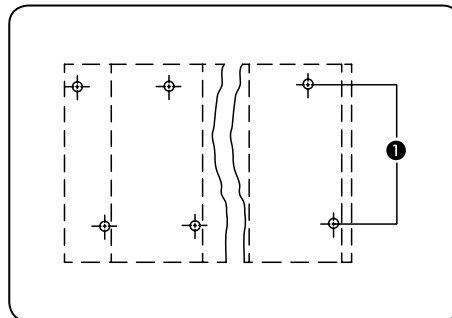
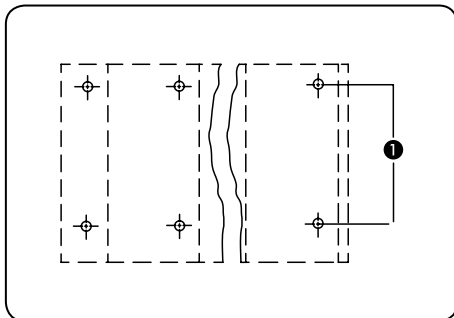

Solder pins in line

Solder pins staggered by half the pin spacing

- ① Voltage rating between adjacent poles:  
320 V/4 kV/3 (III)  
320 V/4 kV/2 (III)  
630 V/4 kV/2 (II)

Pole No.	Item No.	Pack. Unit	Pole No.	Item No.	Pack. Unit
Double-deck terminal strip, 2 solder pins in line, orange			Double-deck terminal strip, 2 solder pins staggered by half the pin spacing, orange		
2 x 2	736-802	112	2 x 2	736-852	112
3 x 2	736-803	70	3 x 2	736-853	70
4 x 2	736-804	49	4 x 2	736-854	49
6 x 2	736-806	28	6 x 2	736-856	28
8 x 2	736-808	21	8 x 2	736-858	21
12 x 2	736-812	14	12 x 2	736-862	14

# 1 Triple-Deck PCB Terminal Strips 2.5 mm<sup>2</sup> Pin Spacing 5 mm, 7.5 mm, 10 mm 737 Series

54

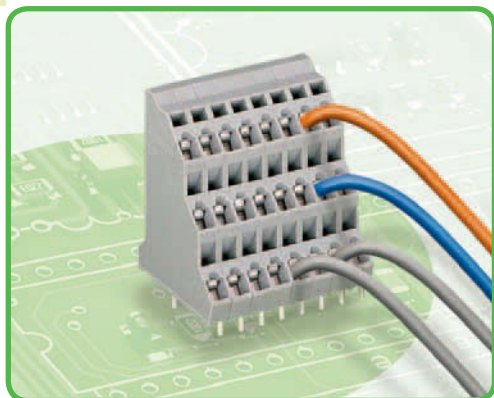

- Terminal strips with screwdriver-actuated CAGE CLAMP®
- High-density, triple-deck design for space-efficient wiring of multiple conductors in confined areas
- Custom direct marking for all termination levels
- Terminal strips with commoning strips for distributing potentials, see pages 67 – 69

### Technical data:

Pin Spacing	5 mm 0.179 in			7.5 mm 0.295 in			10 mm 0.394 in		
	IEC/EN 60664-1			IEC/EN 60664-1			IEC/EN 60664-1		
Rating per									
Overtoltage category	III	III	II	III	III	II	III	III	II
Pollution degree	3	2	2	3	2	2	3	2	2
Rated voltage	250 V	320 V	630 V	400 V	630 V	1000 V	630 V	1000 V	1000 V
Rated surge voltage	4 kV	4 kV	4 kV	6 kV	6 kV	6 kV	8 kV	8 kV	8 kV
Nominal current	21 A	21 A	21 A	21 A	21 A	21 A	21 A	21 A	21 A
Approvals per	UL/CSA			UL/CSA			UL/CSA		
Use group UL 1059	B	C	D	B	C	D	B	C	D
Rated voltage	300 V	-	300 V	300 V	-	300 V	300 V	-	300 V
Nominal current UL	10 A	-	10 A	10 A	-	10 A	10 A	-	10 A
Nominal current CSA	10 A	-	10 A	10 A	-	10 A	10 A	-	10 A

### Conductor and solder pin data:

Connection technology	CAGE CLAMP®
Conductor size: solid	0.08 – 2.5 mm <sup>2</sup>
Conductor size: fine-stranded	0.08 – 2.5 mm <sup>2</sup>
Conductor size: fine-stranded	0.25 – 1.5 mm <sup>2</sup> (with insulated ferrule)
Conductor size: fine-stranded	0.25 – 2.5 mm <sup>2</sup> (with uninsulated ferrule)
AWG	28 – 12 (12: THHN, THWN)
Strip length	5 – 6 mm / 0.20 – 0.24 in
Conductor entry angle	45° to PCB
Solder pin: length/width	4 mm / 0.7 x 0.7 mm
Solder pin: drilled hole diameter	1.3 <sup>+0.1</sup> mm

### Material data:

Material group	I
Insulation material	Nylon 6.6 (PA 6.6)
Flammability rating per UL 94	V0
Lower/Upper temperature limit	-60°C / +105°C
Clamping spring material	Chrome-nickel spring steel (CrNi)
Contact material	Electrolytic copper (E <sub>cu</sub> )
Contact plating	tin-plated

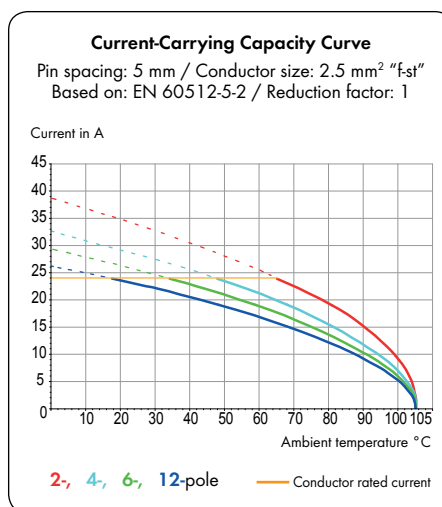

### 737 Series accessories:

Page:

Marking accessories	540 – 543
Operating tools	526 – 528
Commoning strips	67 – 69
Test plug modules	198 – 199



# Triple-Deck PCB Terminal Strips 2.5 mm<sup>2</sup>

Solder pins in line Pin spacing 5 mm / 0.197 in		Solder pins staggered Pin spacing 5 mm / 0.197 in	
0.08 - 2.5 mm <sup>2</sup>	AWG 28 - 12	0.08 - 2.5 mm <sup>2</sup>	AWG 28 - 12
320 V/4 kV/2 21 A	300 V/10 A	320 V/4 kV/2 21 A	300 V/10 A

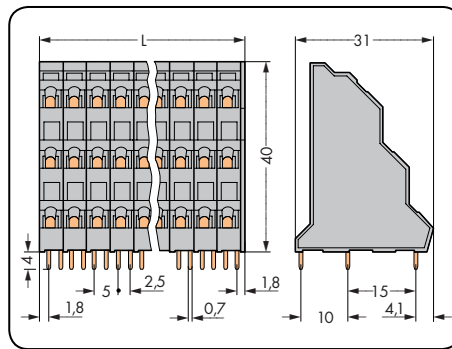
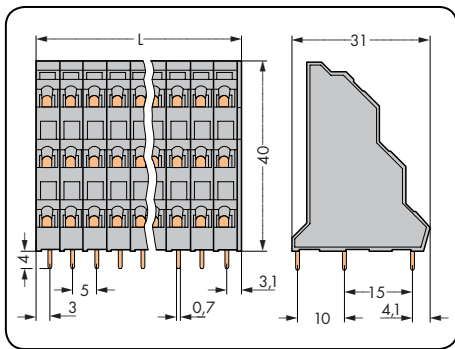
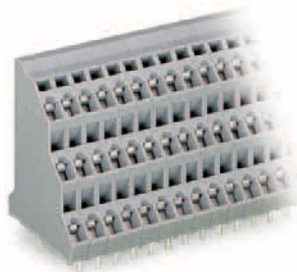

L = (pole no. x pin spacing) + 1 mm

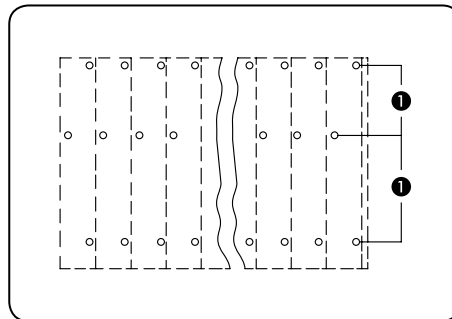
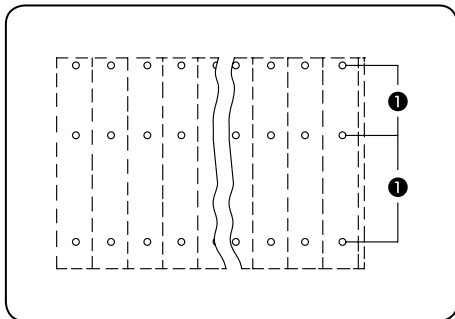

Solder pins in line

Solder pins for deck 2 staggered by half the pin spacing

- ① Voltage rating between adjacent poles:  
320 V/4 kV/3 (III)  
320 V/4 kV/2 (III)  
630 V/4 kV/2 (II)

Pole No.	Item No.	Pack. Unit	Pole No.	Item No.	Pack. Unit
Triple-deck terminal strip, 3 solder pins in line, gray			Triple-deck terminal strip, solder pins for deck 2 staggered by half the pin spacing, gray		
2 x 3	737-102	92	2 x 3	737-202	92
3 x 3	737-103	64	3 x 3	737-203	64
4 x 3	737-104	48	4 x 3	737-204	48
6 x 3	737-106	32	6 x 3	737-206	32
8 x 3	737-108	24	8 x 3	737-208	24
12 x 3	737-112	16	12 x 3	737-212	16
16 x 3	737-116	12	16 x 3	737-216	12
24 x 3	737-124	8	24 x 3	737-224	8

# Triple-Deck PCB Terminal Strips 2.5 mm<sup>2</sup> 737 Series

Solder pins in line Pin spacing 7.5 mm / 0.295 in		Solder pins staggered Pin spacing 7.5 mm / 0.295 in	
0.08 - 2.5 mm <sup>2</sup>	AWG 28 - 12	0.08 - 2.5 mm <sup>2</sup>	AWG 28 - 12
630 V/6 kV/2 21 A	300 V/10 A	630 V/6 kV/2 21 A	300 V/10 A

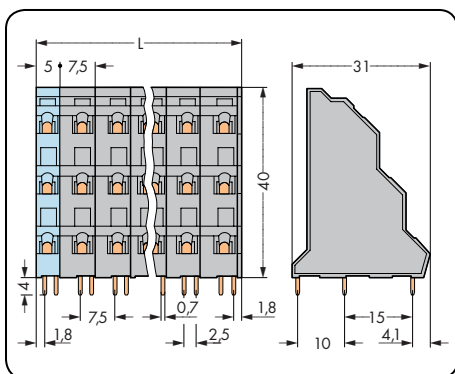
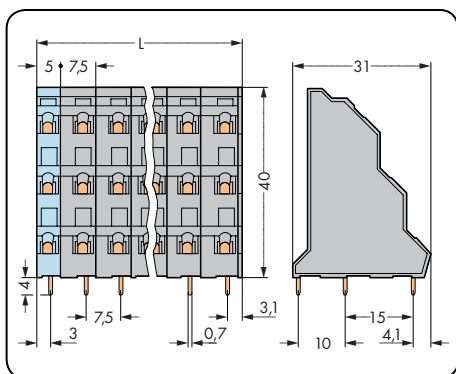
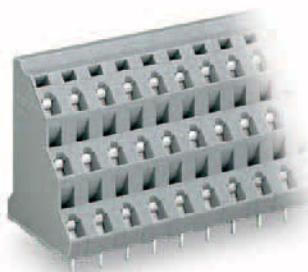

$L = (\text{pole no.} - 1) \times \text{pin spacing} + 5 \text{ mm} + 1 \text{ mm}$

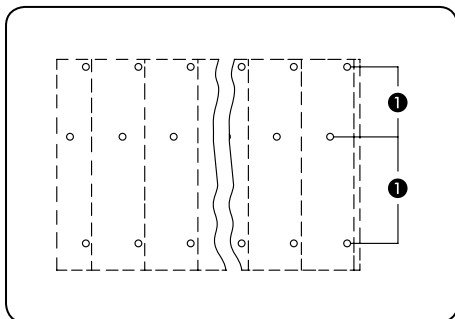
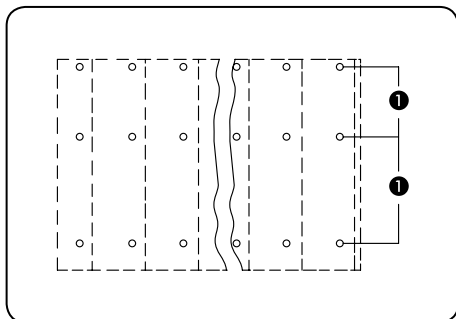

Solder pins in line

Solder pins for deck 2 staggered by half the pin spacing

- ① Voltage rating between adjacent poles:  
320 V/4 kV/3 (III)  
320 V/4 kV/2 (III)  
630 V/4 kV/2 (II)

Pole No.	Item No.	Pack. Unit	Pole No.	Item No.	Pack. Unit
<b>Triple-deck terminal strip, 3 solder pins in line, gray</b>			<b>Triple-deck terminal strip, solder pins for deck 2 staggered by half the pin spacing, gray</b>		
2 x 3	737-502	76	2 x 3	737-552	76
3 x 3	737-503	48	3 x 3	737-553	48
4 x 3	737-504	36	4 x 3	737-554	36
6 x 3	737-506	24	6 x 3	737-556	24
8 x 3	737-508	16	8 x 3	737-558	16
12 x 3	737-512	8	12 x 3	737-562	8
16 x 3	737-516	8	16 x 3	737-566	8

# Triple-Deck PCB Terminal Strips 2.5 mm<sup>2</sup>

CAGE CLAMP®

1  
57

1

Solder pins in line Pin spacing 10 mm / 0.394 in		Solder pins staggered Pin spacing 10 mm / 0.394 in	
0.08 - 2.5 mm <sup>2</sup>	AWG 28 - 12	0.08 - 2.5 mm <sup>2</sup>	AWG 28 - 12
1000 V/8 kV/2 21 A	300 V/10 A	1000 V/8 kV/2 21 A	300 V/10 A

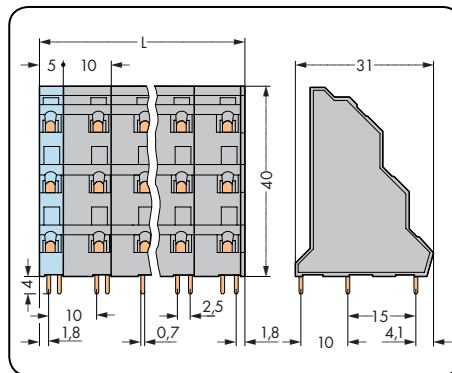
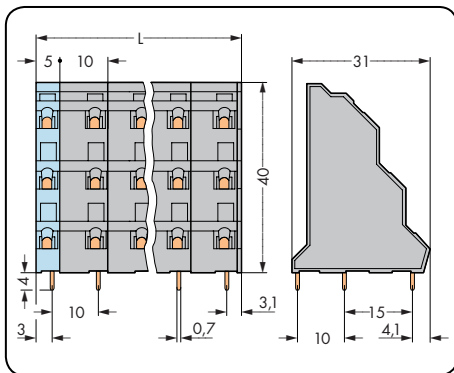

$L = (\text{pole no.} - 1) \times \text{pin spacing} + 5 \text{ mm} + 1 \text{ mm}$

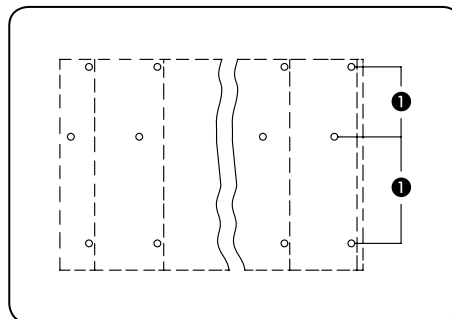
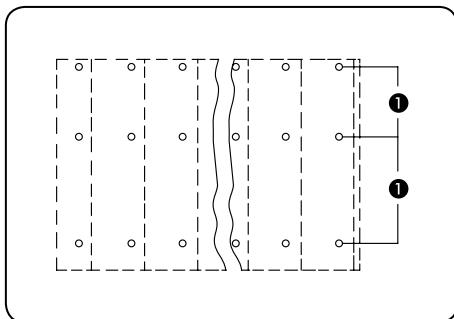

Solder pins in line

Solder pins for deck 2 staggered by half the pin spacing

- ① Voltage rating between adjacent poles:  
 320 V/4 kV/3 (III)  
 320 V/4 kV/2 (III)  
 630 V/4 kV/2 (II)

Pole No.	Item No.	Pack. Unit	Pole No.	Item No.	Pack. Unit
Triple-deck terminal strip, 3 solder pins in line, gray			Triple-deck terminal strip, solder pins for deck 2 staggered by half the pin spacing, gray		
2 x 3	737-702	64	2 x 3	737-752	64
3 x 3	737-703	40	3 x 3	737-753	40
4 x 3	737-704	28	4 x 3	737-754	28
6 x 3	737-706	16	6 x 3	737-756	16
8 x 3	737-708	12	8 x 3	737-758	12
12 x 3	737-712	8	12 x 3	737-762	8

For other lengths or colors, mixed-color, as well as direct marking, please contact factory.

# Triple-Deck PCB Terminal Strips 2.5 mm<sup>2</sup> Pin Spacing 5.08 mm, 7.62 mm, 10.16 mm 737 Series

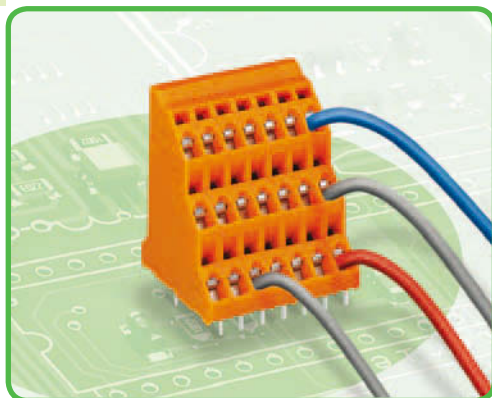

- Terminal strips with screwdriver-actuated CAGE CLAMP®
- High-density, triple-deck design for space-efficient wiring of multiple conductors in confined areas
- Custom direct marking for all termination levels
- Terminal strips with commoning strips for distributing potentials, see pages 67 – 69

### Technical data:

Pin Spacing	5.08 mm 0.2 in			7.62 mm 0.3 in			10.16 mm 0.4 in		
	IEC/EN 60664-1			IEC/EN 60664-1			IEC/EN 60664-1		
Rating per	IEC/EN 60664-1			IEC/EN 60664-1			IEC/EN 60664-1		
Overtoltage category	III	III	II	III	III	II	III	III	II
Pollution degree	3	2	2	3	2	2	3	2	2
Rated voltage	250 V	320 V	630 V	400 V	630 V	1000 V	630 V	1000 V	1000 V
Rated surge voltage	4 kV	4 kV	4 kV	6 kV	6 kV	6 kV	8 kV	8 kV	8 kV
Nominal current	21 A	21 A	21 A	21 A	21 A	21 A	21 A	21 A	21 A
Approvals per	UL/CSA			UL/CSA			UL/CSA		
Use group UL 1059	B	C	D	B	C	D	B	C	D
Rated voltage	300 V	-	300 V	300 V	-	300 V	300 V	-	300 V
Nominal current UL	10 A	-	10 A	10 A	-	10 A	10 A	-	10 A
Nominal current CSA	10 A	-	10 A	10 A	-	10 A	10 A	-	10 A

### Conductor and solder pin data:

Connection technology	CAGE CLAMP®
Conductor size: solid	0.08 – 2.5 mm <sup>2</sup>
Conductor size: fine-stranded	0.08 – 2.5 mm <sup>2</sup>
Conductor size: fine-stranded	0.25 – 1.5 mm <sup>2</sup> (with insulated ferrule)
Conductor size: fine-stranded	0.25 – 2.5 mm <sup>2</sup> (with uninsulated ferrule)
AWG	28 – 12 (12: THHN, THWN)
Strip length	5 – 6 mm / 0.20 – 0.24 in
Conductor entry angle	45° to PCB
Solder pin: length/width	4 mm / 0.7 x 0.7 mm
Solder pin: drilled hole diameter	1.3 <sup>+0.1</sup> mm

### Material data:

Material group	I
Insulation material	Nylon 6.6 (PA 6.6)
Flammability rating per UL 94	V0
Lower/Upper temperature limit	-60°C / +105°C
Clamping spring material	Chrome-nickel spring steel (CrNi)
Contact material	Electrolytic copper (E <sub>Cu</sub> )
Contact plating	tin-plated

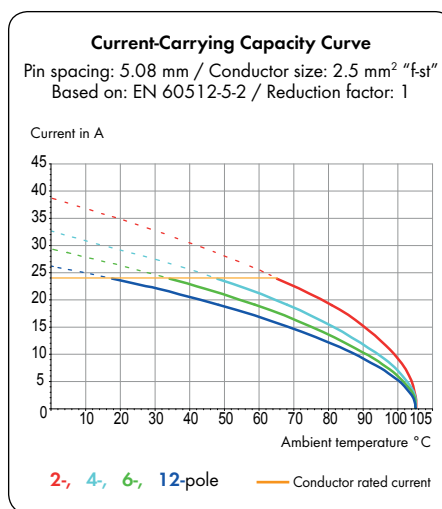

### 737 Series accessories:

### Page:

Marking accessories	540 – 543
Operating tools	526 – 528
Commoning strips	67 – 69
Test plug modules	198 – 199

# Triple-Deck PCB Terminal Strips 2.5 mm<sup>2</sup>

CAGE CLAMP®

Solder pins in line Pin spacing 5.08 mm / 0.2 in		Solder pins staggered Pin spacing 5.08 mm / 0.2 in	
0.08 - 2.5 mm <sup>2</sup>	AWG 28 - 12	0.08 - 2.5 mm <sup>2</sup>	AWG 28 - 12
320 V/4 kV/2 21 A	300 V/10 A	320 V/4 kV/2 21 A	300 V/10 A

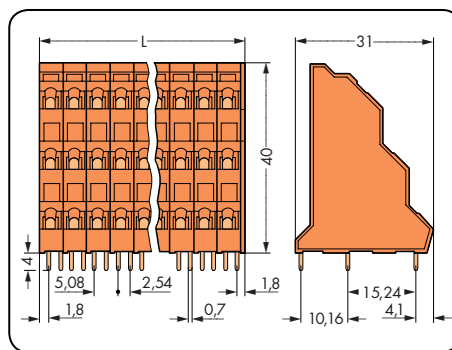
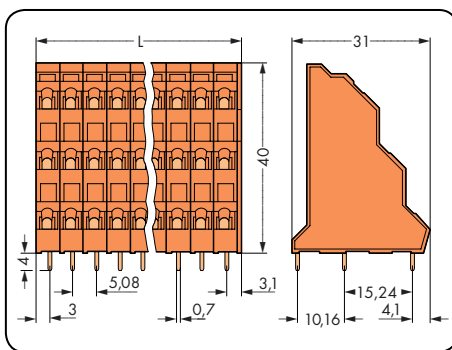
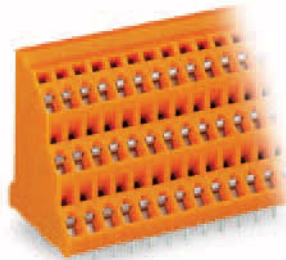
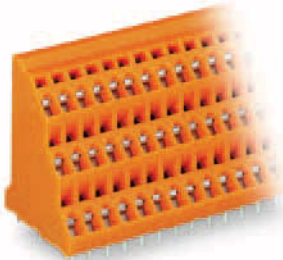

L = (pole no. x pin spacing) + 1 mm

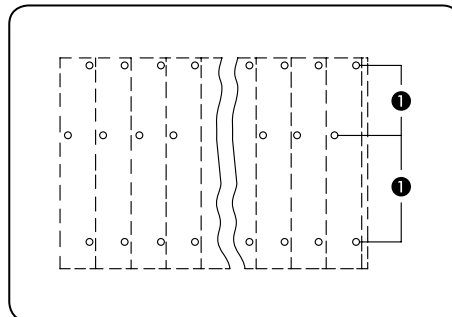
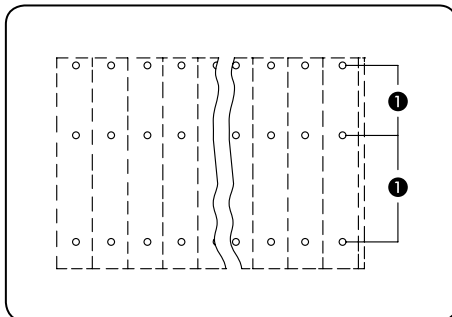

Solder pins in line

Solder pins for deck 2 staggered by half the pin spacing

- ① Voltage rating between adjacent poles:  
320 V/4 kV/3 (III)  
320 V/4 kV/2 (III)  
630 V/4 kV/2 (II)

Pole No.	Item No.	Pack. Unit	Pole No.	Item No.	Pack. Unit
Triple-deck terminal strip, 3 solder pins in line, orange			Triple-deck terminal strip, solder pins for deck 2 staggered by half the pin spacing, orange		
2 x 3	737-302	92	2 x 3	737-402	92
3 x 3	737-303	64	3 x 3	737-403	64
4 x 3	737-304	48	4 x 3	737-404	48
6 x 3	737-306	32	6 x 3	737-406	32
8 x 3	737-308	24	8 x 3	737-408	24
12 x 3	737-312	16	12 x 3	737-412	16
16 x 3	737-316	12	16 x 3	737-416	12
24 x 3	737-324	8	24 x 3	737-424	8



# 1 Triple-Deck PCB Terminal Strips 2.5 mm<sup>2</sup> 737 Series

60

Solder pins in line Pin spacing 7.62 mm / 0.3 in		Solder pins staggered Pin spacing 7.62 mm / 0.3 in	
0.08 - 2.5 mm <sup>2</sup>	AWG 28 - 12	0.08 - 2.5 mm <sup>2</sup>	AWG 28 - 12
630 V/6 kV/2 21 A	300 V/10 A	630 V/6 kV/2 21 A	300 V/10 A

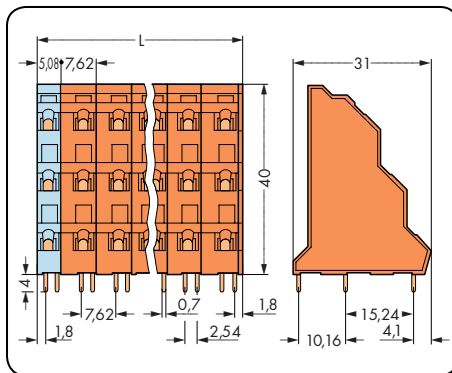
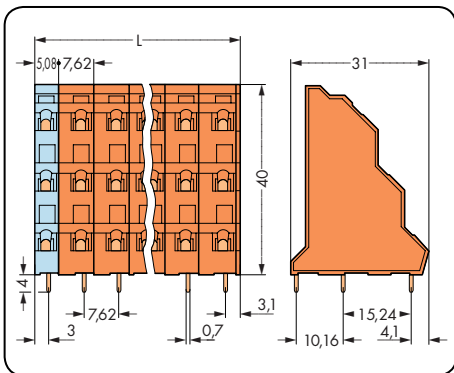
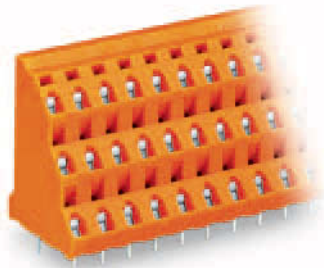
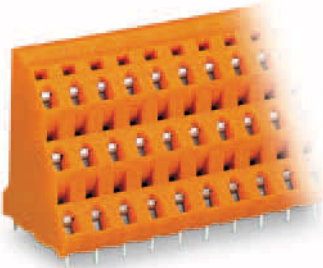

$L = (\text{pole no.} - 1) \times \text{pin spacing} + 5.08 \text{ mm} + 1 \text{ mm}$

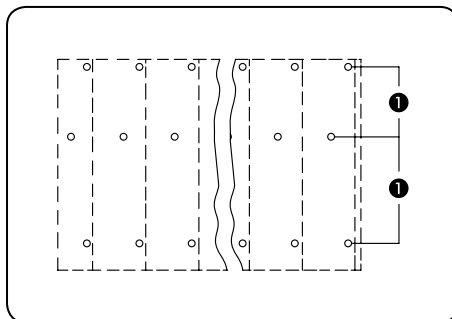
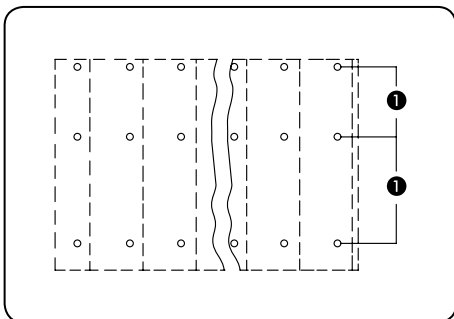

Solder pins in line

Solder pins for deck 2 staggered by half the pin spacing

- ① Voltage rating between adjacent poles:  
320 V/4 kV/3 (III)  
320 V/4 kV/2 (III)  
630 V/4 kV/2 (II)

Pole No.	Item No.	Pack. Unit	Pole No.	Item No.	Pack. Unit
<b>Triple-deck terminal strip, 3 solder pins in line, orange</b>			<b>Triple-deck terminal strip, solder pins for deck 2 staggered by half the pin spacing, orange</b>		
2 x 3	737-602	76	2 x 3	737-652	76
3 x 3	737-603	48	3 x 3	737-653	48
4 x 3	737-604	36	4 x 3	737-654	36
6 x 3	737-606	20	6 x 3	737-656	20
8 x 3	737-608	16	8 x 3	737-658	16
12 x 3	737-612	8	12 x 3	737-662	8
16 x 3	737-616	8	16 x 3	737-666	8

Please contact factory for other lengths, colors, mixed-color terminal strips, or direct marking.

# Triple-Deck PCB Terminal Strips 2.5 mm<sup>2</sup>

CAGE CLAMP®

Solder pins in line Pin spacing 10.16 mm / 0.4 in		Solder pins staggered Pin spacing 10.16 mm / 0.4 in	
0.08 - 2.5 mm <sup>2</sup>	AWG 28 - 12	0.08 - 2.5 mm <sup>2</sup>	AWG 28 - 12
1000 V/8 kV/2 21 A	300 V/10 A	1000 V/8 kV/2 21 A	300 V/10 A

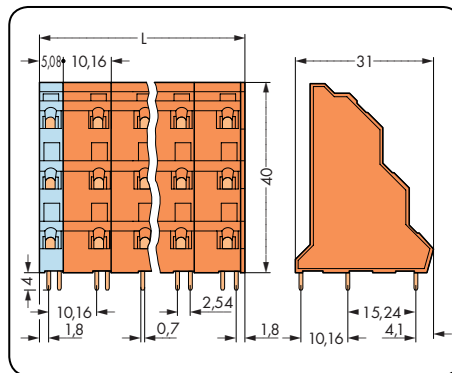
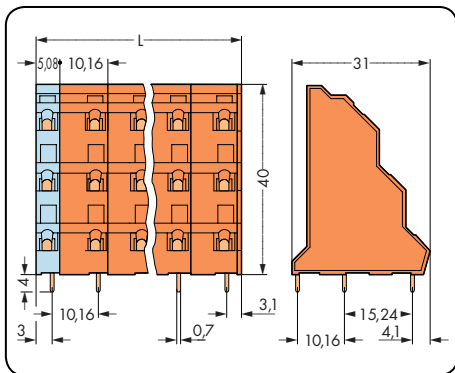
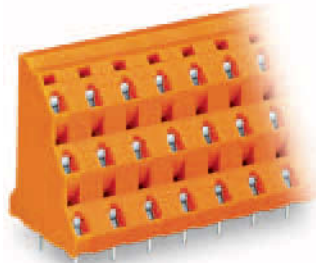
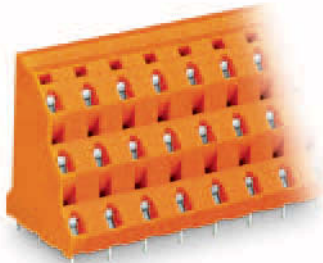

$L = (\text{pole no.} - 1) \times \text{pin spacing} + 5.08 \text{ mm} + 1 \text{ mm}$

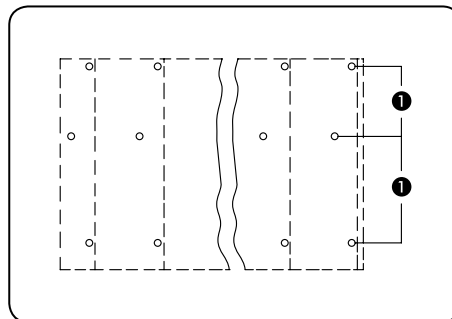
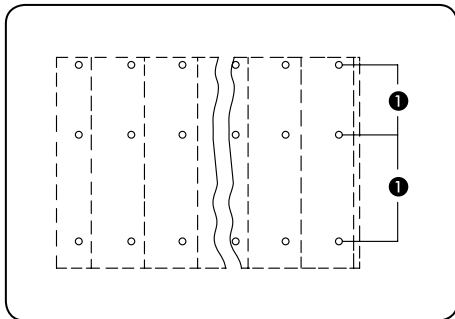

Solder pins in line

Solder pins for deck 2 staggered by half the pin spacing

- ① Voltage rating between adjacent poles:  
320 V/4 kV/3 (III)  
320 V/4 kV/2 (III)  
630 V/4 kV/2 (II)

Pole No.	Item No.	Pack. Unit	Pole No.	Item No.	Pack. Unit
Triple-deck terminal strip, 3 solder pins in line, orange			Triple-deck terminal strip, solder pins for deck 2 staggered by half the pin spacing, orange		
2 x 3	737-802	64	2 x 3	737-852	64
3 x 3	737-803	40	3 x 3	737-853	40
4 x 3	737-804	28	4 x 3	737-854	28
6 x 3	737-806	16	6 x 3	737-856	16
8 x 3	737-808	12	8 x 3	737-858	12
12 x 3	737-812	8	12 x 3	737-862	8

# Quadruple-Deck PCB Terminal Strips 2.5 mm<sup>2</sup> Pin Spacing 5 mm 738 Series

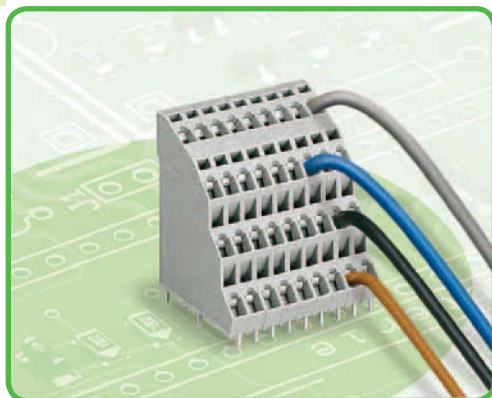

- Terminal strips with screwdriver-actuated CAGE CLAMP®
- High-density, quadruple-deck design for space-efficient wiring of multiple conductors in confined areas
- Angled conductor entry and CAGE CLAMP® actuation streamline operation
- Custom direct marking for all termination levels
- Terminal strips with commoning strips for distributing potentials, see pages 67 - 69

### Technical data:

Pin Spacing	5 mm 0.179 in		
Rating per	IEC/EN 60664-1		
Overtension category	III	III	II
Pollution degree	3	2	2
Rated voltage	250 V	320 V	630 V
Rated surge voltage	4 kV	4 kV	4 kV
Nominal current	18 A	18 A	18 A
Approvals per	UL/CSA		
Use group UL 1059	B	C	D
Rated voltage	300 V	-	300
Nominal current UL	10 A	-	10 A
Nominal current CSA	10 A	-	10 A

### Conductor and solder pin data:

Connection technology	CAGE CLAMP®
Conductor size: solid	0.08 - 2.5 mm <sup>2</sup>
Conductor size: fine-stranded	0.08 - 2.5 mm <sup>2</sup>
Conductor size: fine-stranded	0.25 - 1.5 mm <sup>2</sup> (with insulated ferrule)
Conductor size: fine-stranded	0.25 - 2.5 mm <sup>2</sup> (with uninsulated ferrule)
AWG	28 - 12 (12: THHN, THWN)
Strip length	5 - 6 mm / 0.20 - 0.24 in
Conductor entry angle	45° to PCB
Solder pin: length/width	4 mm / 0.7 x 0.7 mm
Solder pin: drilled hole diameter	1.3 <sup>+0.1</sup> mm

### Material data:

Material group	I
Insulating material	Nylon 6.6 (PA 6.6)
Flammability rating per UL 94	V0
Lower/Upper temperature limit	-60°C / +105°C
Clamping spring material	Chrome-nickel spring steel (CrNi)
Contact material	Electrolytic copper (E <sub>Cu</sub> )
Contact plating	tin-plated

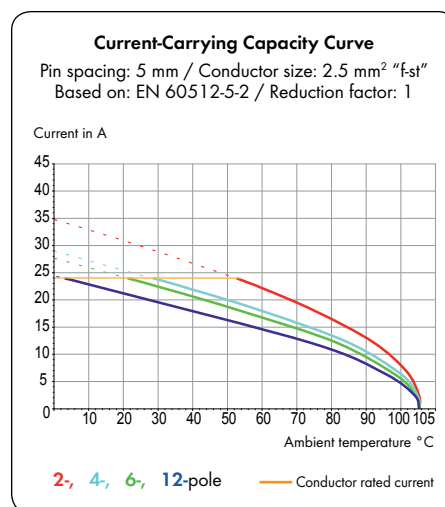

### 738 Series accessories:

### Page:

Marking accessories	540 - 543
Operating tools	526 - 528
Commoning strips	67 - 69
Test plug modules	198 - 199

# Quadruple-Deck PCB Terminal Strips 2.5 mm<sup>2</sup>

CAGE CLAMP®

1

63

1

Pin spacing 5 mm / 0.197 in		Pin spacing 5 mm / 0.197 in	
0.08 - 2.5 mm <sup>2</sup>	AWG 28 - 12	0.08 - 2.5 mm <sup>2</sup>	AWG 28 - 12
320 V/4 kV/2 18 A	300 V/10 A	320 V/4 kV/2 18 A	300 V/10 A

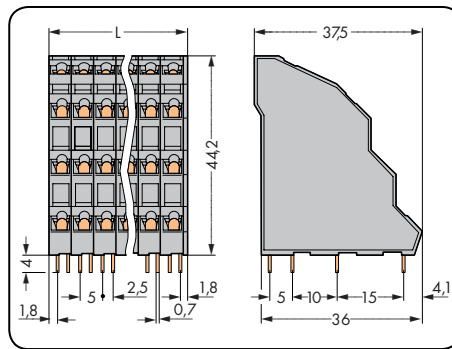
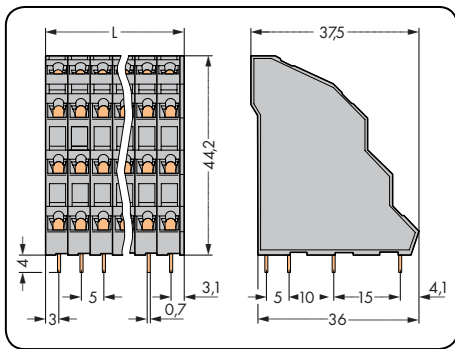
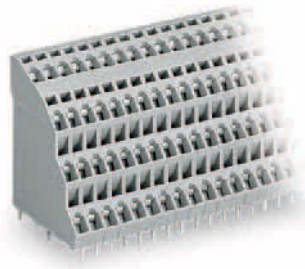
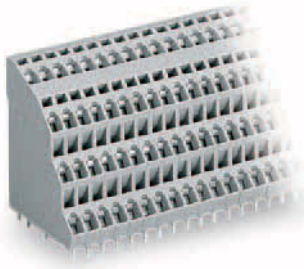

L = (pole no. x pin spacing) + 1 mm

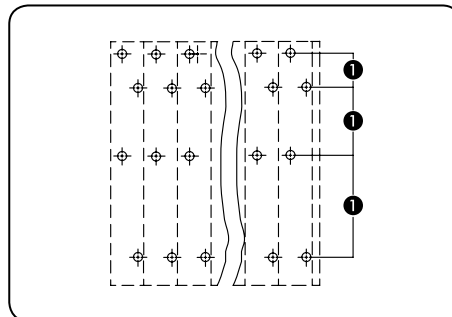
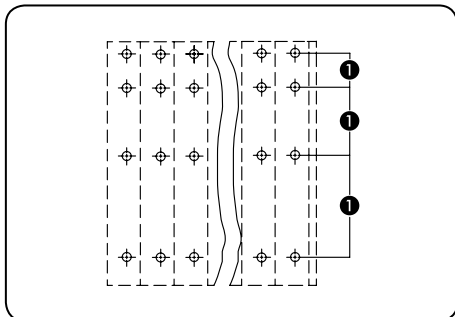

Solder pins in line

- ① Voltage rating between adjacent poles:  
320 V/4 kV/3 (III)  
320 V/4 kV/2 (III)  
630 V/4 kV/2 (II)

Solder pins for deck 2 and 4 staggered by half the pin spacing

Pole No.	Item No.	Pack. Unit	Pole No.	Item No.	Pack. Unit
<b>Quadruple-deck terminal strip, 4 solder pins in line, gray</b>			<b>Quadruple-deck terminal strip, solder pins for deck 2 and 4 staggered by half the pin spacing, gray</b>		
2 x 4	738-102	72	2 x 4	738-202	72
3 x 4	738-103	48	3 x 4	738-203	48
4 x 4	738-104	36	4 x 4	738-204	36
6 x 4	738-106	24	6 x 4	738-206	24
8 x 4	738-108	18	8 x 4	738-208	18
12 x 4	738-112	12	12 x 4	738-212	12
16 x 4	738-116	9	16 x 4	738-216	9
24 x 4	738-124	6	24 x 4	738-224	6

Please contact factory for other lengths, colors, mixed-color terminal strips, or direct marking.

WAGO®

# Quadruple-Deck PCB Terminal Strips 2.5 mm<sup>2</sup> Pin Spacing 5.08 mm 738 Series

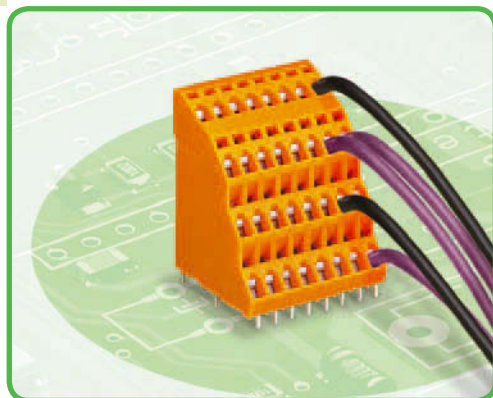

- Terminal strips with screwdriver-actuated CAGE CLAMP®
- High-density, quadruple-deck design for space-efficient wiring of multiple conductors in confined areas
- Angled conductor entry and CAGE CLAMP® actuation streamline operation
- Custom direct marking for all termination levels
- Terminal strips with commoning strips for distributing potentials, see pages 67 - 69

### Technical data:

Pin Spacing	5.08 mm 0.2 in		
Rating per	IEC/EN 60664-1		
Overvoltage category	III	III	II
Pollution degree	3	2	2
Rated voltage	250 V	320 V	630 V
Rated surge voltage	4 kV	4 kV	4 kV
Nominal current	18 A	18 A	18 A
Approvals per	UL/CSA		
Use group UL 1059	B	C	D
Rated voltage	300 V	-	300
Nominal current UL	10 A	-	10 A
Nominal current CSA	10 A	-	10 A

### Conductor and solder pin data:

Connection technology	CAGE CLAMP®
Conductor size: solid	0.08 - 2.5 mm <sup>2</sup>
Conductor size: fine-stranded	0.08 - 2.5 mm <sup>2</sup>
Conductor size: fine-stranded	0.25 - 1.5 mm <sup>2</sup> (with insulated ferrule)
Conductor size: fine-stranded	0.25 - 2.5 mm <sup>2</sup> (with uninsulated ferrule)
AWG	28 - 12 (12: THHN, THWN)
Strip length	5 - 6 mm / 0.20 - 0.24 in
Conductor entry angle	45° to PCB
Solder pin: length/width	4 mm / 0.7 x 0.7 mm
Solder pin: drilled hole diameter	1.3 <sup>+0.1</sup> mm

### Material data:

Material group	I
Insulating material	Nylon 6.6 (PA 6.6)
Flammability rating per UL 94	V0
Lower/Upper temperature limit	-60°C / +105°C
Clamping spring material	Chrome-nickel spring steel (CrNi)
Contact material	Electrolytic copper (E <sub>Cu</sub> )
Contact plating	tin-plated

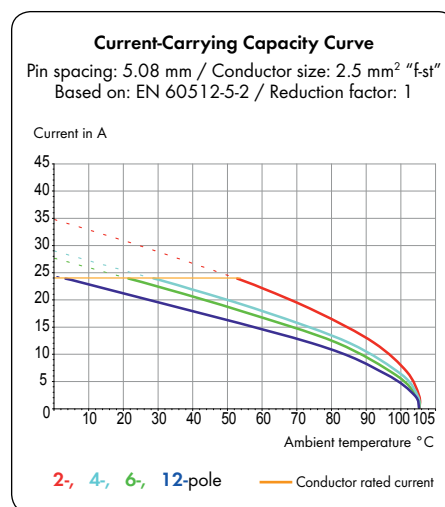

### 738 Series accessories:

### Page:

Marking accessories	540 - 543
Operating tools	526 - 528
Commoning strips	67 - 69
Test plug modules	198 - 199

# Quadruple-Deck PCB Terminal Strips 2.5 mm<sup>2</sup>

CAGE CLAMP®

1

65

1

Pin spacing 5.08 mm / 0.2 in		Pin spacing 5.08 mm / 0.2 in	
0.08 - 2.5 mm <sup>2</sup>	AWG 28 - 12	0.08 - 2.5 mm <sup>2</sup>	AWG 28 - 12
320 V/4 kV/2 18 A	300 V/10 A	320 V/4 kV/2 18 A	300 V/10 A

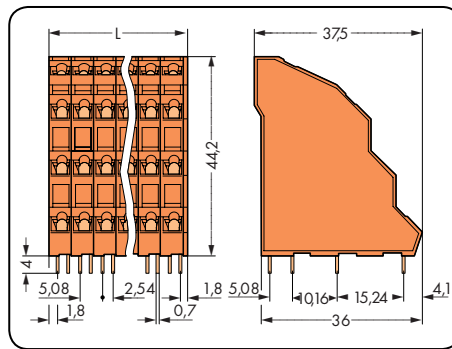
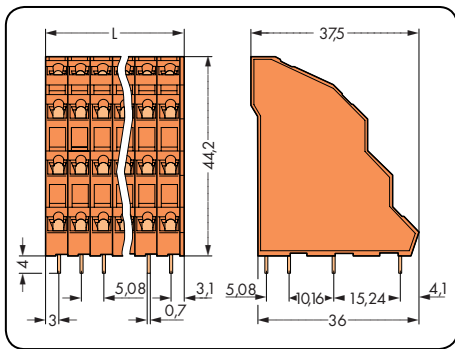
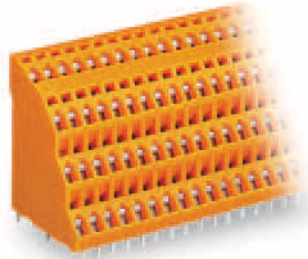
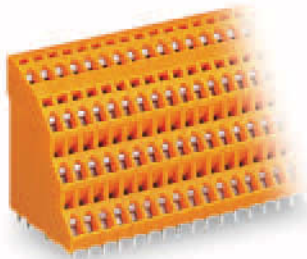

L = (pole no. x pin spacing) + 1 mm

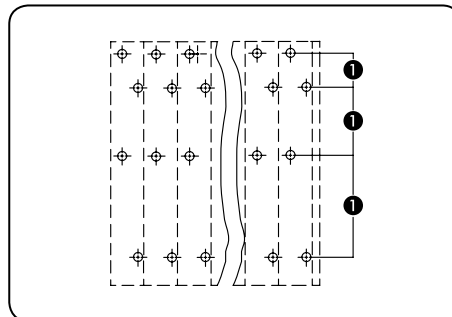
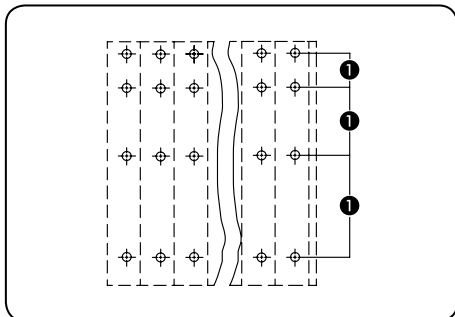

Solder pins in line

- ① Voltage rating between adjacent poles:  
320 V/4 kV/3 (III)  
320 V/4 kV/2 (III)  
630 V/4 kV/2 (II)

Solder pins for deck 2 and 4 staggered by half the pin spacing

Pole No.	Item No.	Pack. Unit	Pole No.	Item No.	Pack. Unit
<b>Quadruple-deck terminal strip, 4 solder pins in line, orange</b>			<b>Quadruple-deck terminal strip, solder pins for deck 2 and 4 staggered by half the pin spacing, orange</b>		
2 x 4	738-302	69	2 x 4	738-402	72
3 x 4	738-303	48	3 x 4	738-403	48
4 x 4	738-304	36	4 x 4	738-404	36
6 x 4	738-306	24	6 x 4	738-406	24
8 x 4	738-308	18	8 x 4	738-408	18
12 x 4	738-312	12	12 x 4	738-412	12
16 x 4	738-316	9	16 x 4	738-416	9
24 x 4	738-324	6	24 x 4	738-424	6

Please contact factory for other lengths, colors, mixed-color terminal strips, or direct marking.

WAGO®



# Combination of Multilevel PCB Terminal Strips 736, 737 and 738 Series

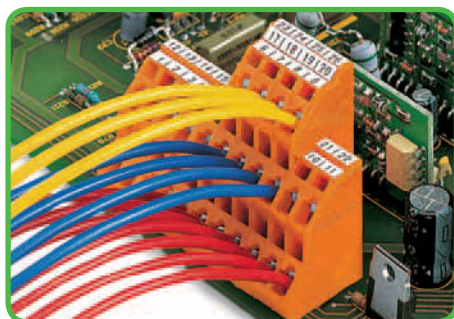
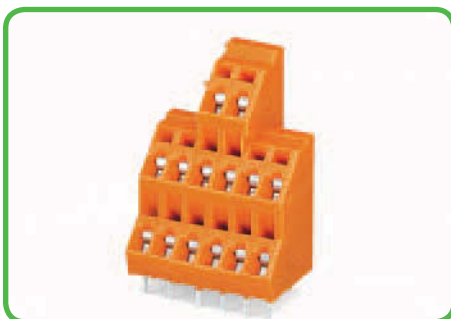
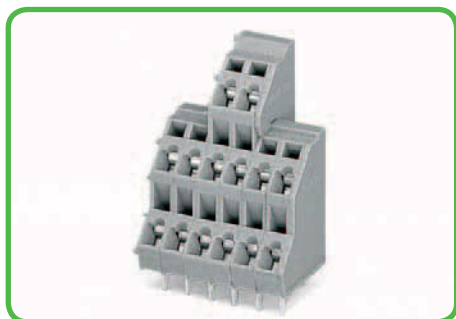

<p>Example of combination: Double-deck (736 Series) and triple-deck terminal strips (737 Series), contact factory</p>	<p>Example of combination: Double-deck (736 Series) and triple-deck terminal strips (737 Series), contact factory</p>	



<p>Example of combination: Triple-deck (737 Series) and quadruple-deck terminal strips (738 Series), contact factory</p>	<p>Example of combination: Triple-deck (737 Series) and quadruple-deck terminal strips (738 Series), contact factory</p>	

# Commoning Strips for PCB Terminal Strips, 236, 255, 256, 257, 736, 737 and 738 Series

<b>Horizontal commoning</b>	<b>Vertical commoning for 736 and 737 Series only starting from pin spacing 7.5 mm / 0.295 in</b>	
-----------------------------	---	--

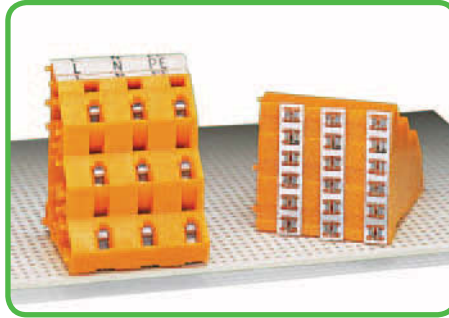

<b>Horizontal commoning</b>	<b>Vertical commoning</b>	
Indicates the connection of adjacent potentials	The solder pins of a terminal block (in line) are commoned to one potential	
<ul style="list-style-type: none"> <li>for example, to common the "+" and "-" supply lines when using terminal blocks for sensor and actuator applications</li> <li>for example, as a ground (earth) commoning strip, where use of the printed circuit traces is not permitted by regulations for continuous looping of ground circuits.</li> </ul>	<ul style="list-style-type: none"> <li>for example, in vertical direction to allow bussing of a 3-conductor supply and distribution terminal up to 10 A.</li> </ul> <p>Also, in some instances, wiring changes can be made without resorting to new PCB schematics and marking.</p>	

### Horizontal commoning

Connection of adjacent terminals

- for example, as "-" supply line in terminal blocks for actuators (max. 10 A total current)
- for example, as ground (earth) commoning strip, where printed circuit traces are not permitted by regulations for continuous looping of ground circuits (max. short-time withstand current 70 A/mm<sup>2</sup> for 1 sec. Standard compliance must be ensured for end use!)

Note: Interruption of horizontal commoning reduces spacing to the adjacent solder pins.

### Vertical commoning

Connection of terminals arranged in front of each other

- for example, as 3-conductor supply and distribution terminal block (up to 10A)

New "commoning" strips are now available for commoning custom designed PCB terminal strips. They allow commoning of pins in either the direction along the assembly, or of all levels in a multi-level terminal strip for each pole. The commoning strips are factory fitted, so please refer to the order form on Pages 1.68 and 1.69.

Commoning allows terminal blocks of common potentials to be created.

These commoning strips are available for the following pin spacings:

- 5 mm, 5.08 mm (up to 20 poles)
- 7.5 mm, 7.62 mm (up to 16 poles)
- 10 mm, 10.16 mm (up to 12 poles).

In cases where not all pins use the commoning strip, unequal height is compensated for by a spacer.

# Order Form "Commoned PCB Terminal Strips"

236, 255, 256, 257  
736, 737, 738 Series

Customer's name: \_\_\_\_\_

Drawing no.: \_\_\_\_\_

WAGO item no.: \_\_\_\_\_

Change note number	5			
	4			
	3			
	2			
	1			
Original	Change note	Date	Name	

Page **of**

Checked by: \_\_\_\_\_

## Ordering example: Horizontal commoning

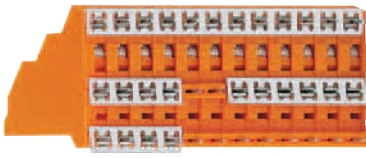

n the case of terminal strips with different pin spacings please state the size of the pin

Item changed Item position	Item no.	Pin spacing	Commoning scheme					Marking															
			B = jumper					level															
End plate: for 736, 737, 738 Series			4	3	2	1	4	3	2	1	Terminal block marking in sense of reading												
1																							
2																							
3																							
4																							
5	737-312	5																					
6																							
7																							
8																							
9																							
10																							
11																							
12																							
13																							
14																							
15																							
16																							
17																							
18																							
19																							

## Design of terminal strip

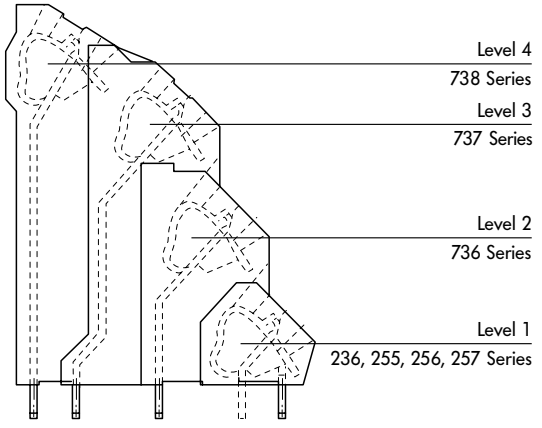

## Ordering example: Vertical commoning

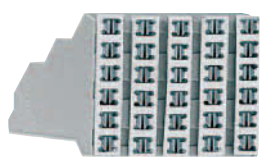

n the case of terminal strips with different pin spacings please state the size of the pin

Item changed Item position	Item no.	Pin spacing	Commoning scheme					Marking															
			B = jumper					level															
End plate: for 736, 737, 738 Series			4	3	2	1	4	3	2	1	Terminal block marking in sense of reading												
1																							
2																							
3																							
4																							
5	737-505	7.5																					
6																							
7																							
8																							
9																							
10																							
11																							
12																							
13																							
14																							
15																							
16																							
17																							
18																							
19																							

Spacers are automatically factory assembled. For terminal strips with different pin spacings, please state the size of the pin spacing instead of the item no.

Item changed Item position	Item no.	Pin spacing	Commoning scheme					Marking															
			B = jumper					level															
End plate: for 736, 737, 738 Series			4	3	2	1	4	3	2	1	Terminal block marking in sense of reading												
1																							
2																							
3																							
4																							
5																							
6																							
7																							
8																							
9																							
10																							
11																							
12																							
13																							
14																							
15																							
16																							
17																							
18																							
19																							
20																							
21																							
22																							
23																							
24																							
25																							
26																							
27																							
28																							
29																							
30																							
31																							
32																							
33																							

End plate for: 236, 255, 256, 257 Series

# Technical Information on "Commoned PCB Terminal Strips"

Use of commoning strips must account for both the specific conditions of the planned application, as well as relevant standards for the normal operating conditions in which operational failures (can) occur.

## Horizontal commoning

(236, 255, 256, 257, 736, 737, 738 Series)

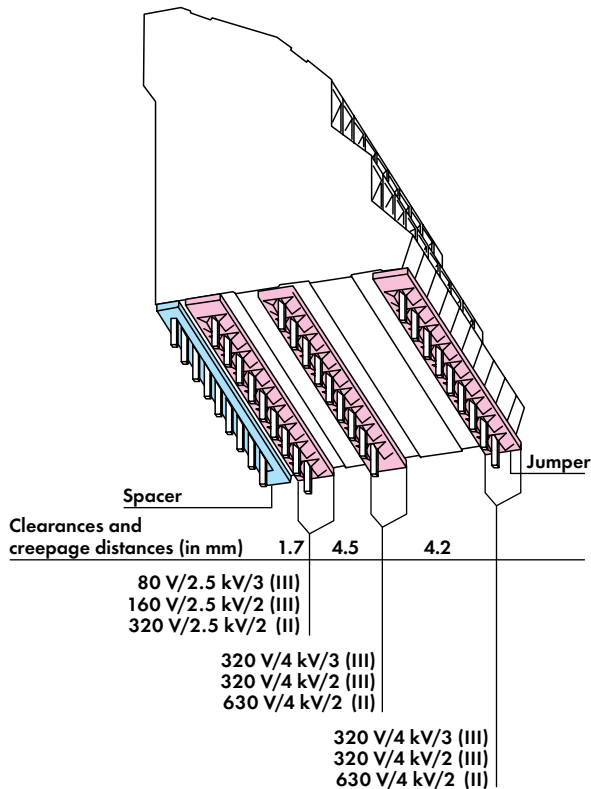

- Mixing of pin spacing only possible with 5 mm, 5.08 mm, 10 mm and 10.16 mm
- Arrangement of solder pins (736, 737, 738 Series) in line or staggered
- 236 Series: Version with only one solder pin cannot be commoned!
- In case of different potentials within one level, ensure that at least one interim terminal block must remain uncommoned in order to maintain the necessary creepage distances and clearances (see also the ordering example).

## Distances to adjacent potentials

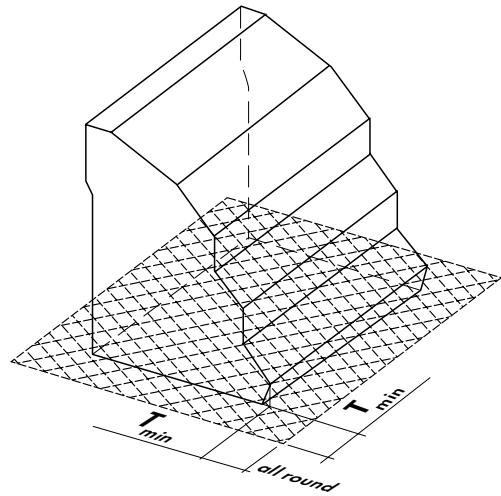

Recommendation:  $T_{min} = 5 \text{ mm}$

Please note that the distance between the commoning strips and adjacent potentials must comply with requirements for the end application as specified in the relevant standard.

## Vertical commoning (only possible with multilevel PCB terminal blocks of 736, 737 Series)

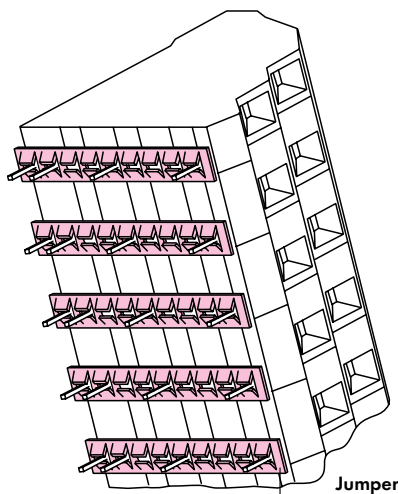

Pin spacing	Creepage distance in mm	Clearance in mm	Voltage
7.5 mm, 7.62 mm	1.7	1.7	80 V/2.5 kV/3 (III)
	1.7	1.7	160 V/2.5 kV/2 (III) 320 V/2.5 kV/2 (II)
10 mm, 10.16 mm	4.2	4.2	320 V/4 kV/3 (III)
	4.2	4.2	320 V/4 kV/2 (III)
	4.2	4.2	630 V/4 kV/2 (II)

- Not possible with 5 mm and 5.08 mm pin spacings!
- Arrangement of solder pins always in line

# PCB Terminal Strips 1.5 mm<sup>2</sup> and 2.5 mm<sup>2</sup>, Press-In Technology Pin Spacing 3.5 mm, 3.81 mm, 5 mm, 5.08 mm, 7.5 mm, 7.62 mm 739 Series

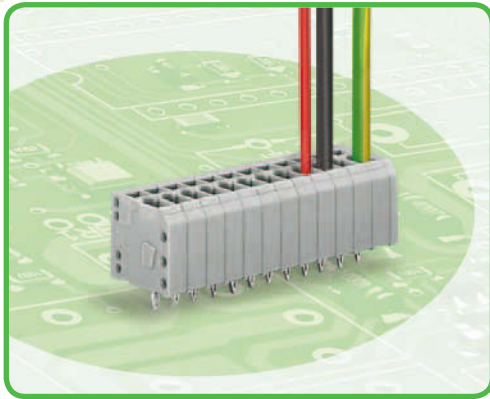

- Terminal strips with screwdriver-actuated CAGE CLAMP®
- Vertical conductor entry and conductor operation provide for space-saving positioning/grouping
- Press-in technology saves costs, no additional soldering process required

### Technical data:

Pin Spacing	3.5 mm, 3.81 mm 0.138 in, 0.15 in			5 mm, 5.08 mm 0.197 in, 0.2 in			7.5 mm, 7.62 mm 0.295 in, 0.3 in		
Rating per	IEC/EN 60664-1			IEC/EN 60664-1			IEC/EN 60664-1		
Overtoltage category	III	III	II	III	III	II	III	III	II
Pollution degree	3	2	2	3	2	2	3	2	2
Rated voltage	160 V	160 V	320 V	250 V	320 V	630 V	500 V	630 V	1000 V
Rated surge voltage	2.5 kV	2.5 kV	2.5 kV	4 kV	4 kV	4 kV	6 kV	6 kV	6 kV
Nominal current	4 A	4 A	4 A	8 A	8 A	8 A	8 A	8 A	8 A
Approvals per	UL/CSA			UL/CSA			UL/CSA		
Use group UL 1059	B	C	D	B	C	D	B	C	D
Rated voltage	300 V	-	300 V	300 V	-	300 V	300 V	-	300 V
Nominal current UL	4 A	-	4 A	8 A	-	8 A	8 A	-	8 A
Nominal current CSA	-	-	-	-	-	-	-	-	-

### Conductor and press-in pin data for 3.5/3.81 mm pin spacing:

Connection technology	CAGE CLAMP®
Conductor size: solid	0.08 - 1.5 mm <sup>2</sup>
Conductor size: fine-stranded	0.08 - 1.5 mm <sup>2</sup>
Conductor size: fine-stranded	0.25 - 1.0 mm <sup>2</sup> (with insulated ferrule)
Conductor size: fine-stranded	0.25 - 1.5 mm <sup>2</sup> (with uninsulated ferrule)
AWG	28 - 14 (14: THHN, THWN)
Strip length	5 - 6 mm / 0.20 - 0.24 in
Conductor entry angle	90° to PCB
Press-in pin: length/width	3.4 mm / 0.6 mm
Press-in pin: recom. drilled hole diameter	1.15 <sup>±0.025</sup> mm
Press-in pin: metal-plated hole diameter	1.0 mm (HAL Sn)
Press-in pin: metal-plated hole diameter	1.0 mm (Chem. Sn)

### Conductor and press-in pin data for 5/5.08 mm and 7.5/7.62 mm pin spacing:

Connection technology	CAGE CLAMP®
Conductor size: solid	0.08 - 2.5 mm <sup>2</sup>
Conductor size: fine-stranded	0.08 - 2.5 mm <sup>2</sup>
Conductor size: fine-stranded	0.25 - 1.5 mm <sup>2</sup> (with insulated ferrule)
Conductor size: fine-stranded	0.25 - 2.5 mm <sup>2</sup> (with uninsulated ferrule)
AWG	28 - 12 (12: THHN, THWN)
Strip length	8 - 9 mm / 0.31 - 0.35 in
Conductor entry angle	90° to PCB
Press-in pin: length/width	3.6 mm / 0.8 mm
Press-in pin: recom. drilled hole diameter	1.6 <sup>±0.025</sup> mm
Press-in pin: metal-plated hole diameter	1.45 mm (HAL Sn)
Press-in pin: metal-plated hole diameter	1.45 mm (Chem. Sn)

### Material data:

Material group	I
Insulating material	Nylon 6.6 (PA 6.6)
Flammability rating per UL 94	V0
Lower/Upper temperature limit	-40°C / +85°C
Clamping spring material	Chrome-nickel spring steel (CrNi)
Contact material	Electrolytic copper (E <sub>cu</sub> ) / Copper alloy for press-in technology
Contact plating	tin-plated

### 739 Series accessories:

### Page:

Marking accessories	540 - 543
Operating tools	526 - 528
Screws	546

Pin spacing 3.5 mm / 0.138 in		With fixing flanges Pin spacing 3.5 mm / 0.138 in		Pin spacing 5 mm / 0.197 in	
0.08 - 1.5 mm <sup>2</sup> 160 V/2.5 kV/2 4 A	AWG 28 - 14 300 V/4 A	0.08 - 1.5 mm <sup>2</sup> 160 V/2.5 kV/2 4 A	AWG 28 - 14 300 V/4 A	0.08 - 2.5 mm <sup>2</sup> 320 V/4 kV/2 8 A	AWG 28 - 12 300 V/8 A

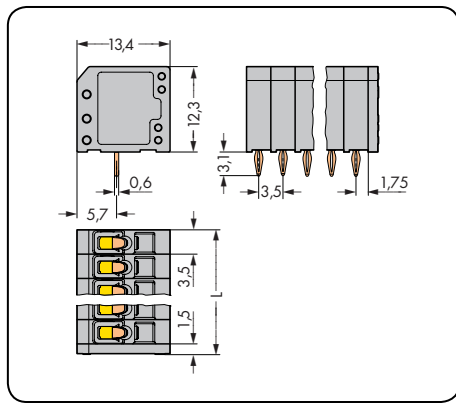
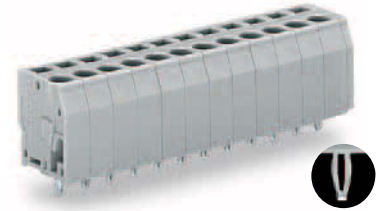

L = pole no. x pin spacing + 1.5 mm

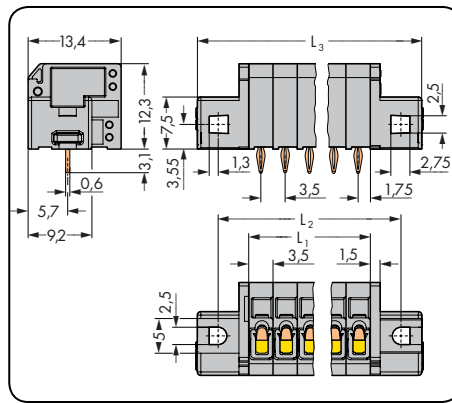

L<sub>1</sub> = pole no. x pin spacing  
L<sub>2</sub> = L<sub>1</sub> + 8.8 mm  
L<sub>3</sub> = L<sub>1</sub> + 14.8 mm

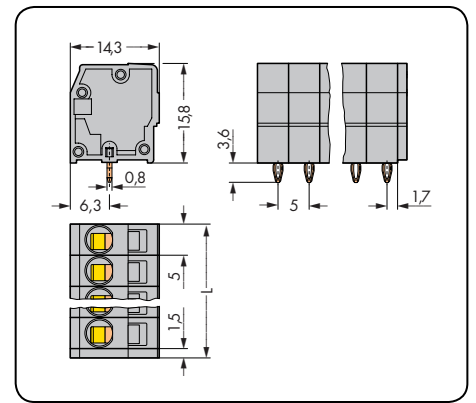

L = (pole no. x pin spacing) + 1.5 mm

Pole No.	Item No.	Pack. Unit	Pole No.	Item No.	Pack. Unit	Pole No.	Item No.	Pack. Unit
<b>Terminal strip, 1 press-in pin/pole, gray</b>			<b>Terminal strip with fixing flanges, 1 press-in pin/pole, gray</b>			<b>Terminal strip, 1 press-in pin/pole, gray</b>		
			2	739-302/100-000/001-000	220 (4 x 55)			
3	739-303/100-000	400 (4 x 100)	3	739-303/100-000/001-000	180 (4 x 45)	3	739-103/100-000	280 (4 x 70)
4	739-304/100-000	300 (4 x 75)	4	739-304/100-000/001-000	160 (4 x 40)	4	739-104/100-000	220 (4 x 55)
5	739-305/100-000	240 (4 x 60)	5	739-305/100-000/001-000	140 (4 x 35)	5	739-105/100-000	180 (4 x 45)
6	739-306/100-000	200 (4 x 50)	6	739-306/100-000/001-000	120 (4 x 30)	6	739-106/100-000	140 (4 x 35)
7	739-307/100-000	180 (4 x 45)	7	739-307/100-000/001-000	120 (4 x 30)	7	739-107/100-000	120 (4 x 30)
8	739-308/100-000	160 (4 x 40)	8	739-308/100-000/001-000	100 (4 x 25)	8	739-108/100-000	100 (4 x 25)
9	739-309/100-000	140 (4 x 35)	9	739-309/100-000/001-000	100 (4 x 25)	9	739-109/100-000	100 (4 x 25)
10	739-310/100-000	120 (4 x 30)	10	739-310/100-000/001-000	80 (4 x 20)	10	739-110/100-000	80 (4 x 20)
12	739-312/100-000	100 (4 x 25)	12	739-312/100-000/001-000	80 (4 x 20)	12	739-112/100-000	60 (4 x 15)

**Item No. Suffixes:**  
**Colored Terminal Strips, 5 mm Pin Spacing**

- black ...-.../100-004
- red ...-.../100-005
- blue ...-.../100-006
- brown ...-.../100-014
- light green ...-.../100-017
- green ...-.../100-023

**Ordering example:**  
Terminal strip, 5 mm pin spacing  
8-pole, brown: 739-108/100-014

**(Production and prices depend on quantity required)**



# PCB Terminal Strips 1.5 mm<sup>2</sup> and 2.5 mm<sup>2</sup>, Press-In Technology

Pin spacing 7.5 mm / 0.295 in		Pin spacing 3.81 mm / 0.15 in		With fixing flanges Pin spacing 3.81 mm / 0.15 in	
0.08 - 2.5 mm <sup>2</sup> 630 V/6 kV/2 8 A	AWG 28 - 12 300 V/8 A	0.08 - 1.5 mm <sup>2</sup> 160 V/2.5 kV/2 4 A	AWG 28 - 14 300 V/4 A	0.08 - 1.5 mm <sup>2</sup> 160 V/2.5 kV/2 4 A	AWG 28 - 14 300 V/4 A

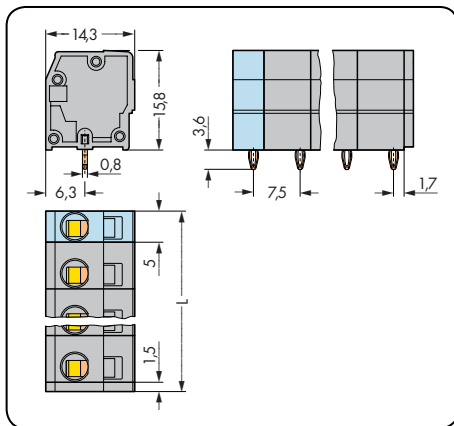
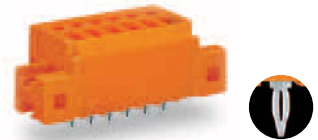
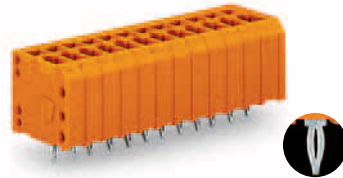

L = (pole no. - 1) x pin spacing + 5 mm + 1.5 mm

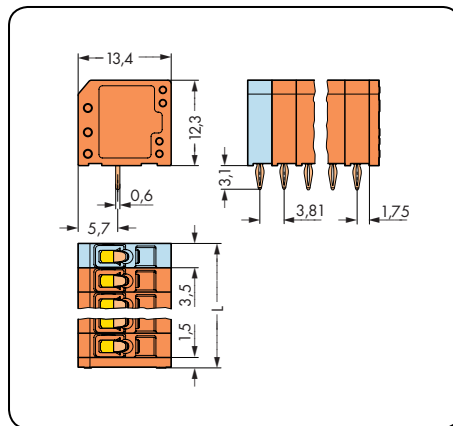

L = pole no. x pin spacing + 3.5 mm + 1.5 mm

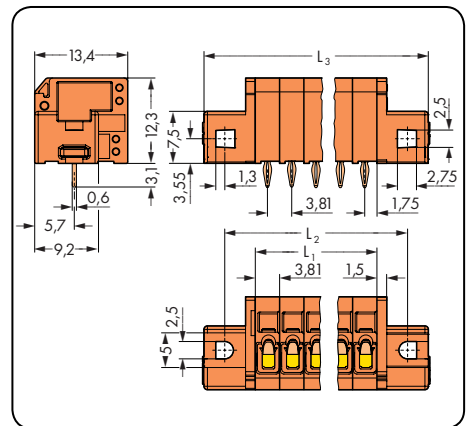

L<sub>1</sub> = pole no. x pin spacing  
L<sub>2</sub> = L<sub>1</sub> + 8.8 mm  
L<sub>3</sub> = L<sub>1</sub> + 14.8 mm

Pole No.	Item No.	Pack. Unit	Pole No.	Item No.	Pack. Unit	Pole No.	Item No.	Pack. Unit
Terminal strip, 1 press-in pin/pole, gray			Terminal strip, 1 press-in pin/pole, orange			Terminal strip with fixing flanges, 1 press-in pin/pole, orange		
3	739-203/100-000	220 (4 x 55)	3	739-333/100-000	360 (4 x 90)	2	739-332/100-000/001-000	200 (4 x 50)
4	739-204/100-000	160 (4 x 40)	4	739-334/100-000	280 (4 x 70)	3	739-333/100-000/001-000	180 (4 x 45)
5	739-205/100-000	120 (4 x 30)	5	739-335/100-000	220 (4 x 55)	4	739-334/100-000/001-000	160 (4 x 40)
6	739-206/100-000	100 (4 x 25)	6	739-336/100-000	180 (4 x 45)	5	739-335/100-000/001-000	140 (4 x 35)
7	739-207/100-000	80 (4 x 20)	7	739-337/100-000	160 (4 x 40)	6	739-336/100-000/001-000	120 (4 x 30)
8	739-208/100-000	80 (4 x 20)	8	739-338/100-000	140 (4 x 35)	7	739-337/100-000/001-000	100 (4 x 25)
9	739-209/100-000	60 (4 x 15)	9	739-339/100-000	120 (4 x 30)	8	739-338/100-000/001-000	100 (4 x 25)
10	739-210/100-000	60 (4 x 15)	10	739-340/100-000	120 (4 x 30)	9	739-339/100-000/001-000	80 (4 x 20)
12	739-212/100-000	40 (4 x 10)	12	739-342/100-000	100 (4 x 25)	10	739-340/100-000/001-000	80 (4 x 20)
						12	739-342/100-000/001-000	60 (4 x 15)

Pin spacing 5.08 mm / 0.2 in		Pin spacing 7.62 mm / 0.3 in	
0.08 - 2.5 mm <sup>2</sup> 320 V/4 kV/2 8 A	AWG 28 - 12 300 V/8 A	0.08 - 2.5 mm <sup>2</sup> 630 V/6 kV/2 8 A	AWG 28 - 12 300 V/8 A

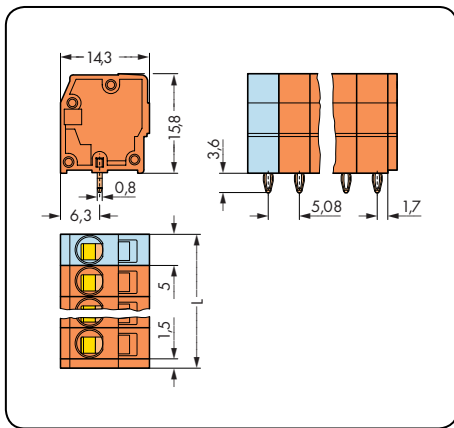
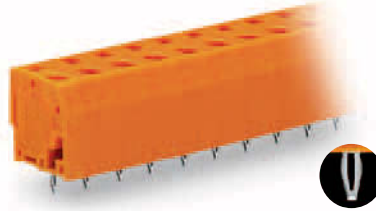

L = (pole no. - 1) x pin spacing + 5 mm + 1.5 mm

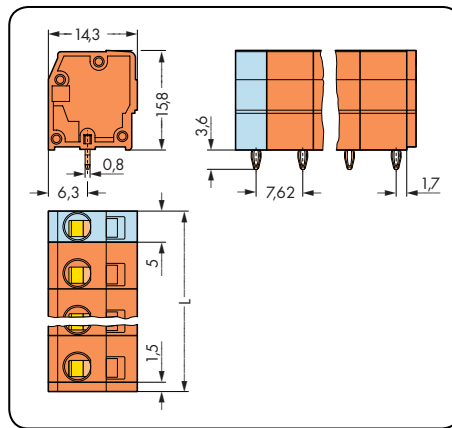

L = (pole no. - 1) x pin spacing + 5 mm + 1.5 mm

### Unique features of WAGO press-in technology:

- Press-in pin features spring-loaded style expanding contact zone to provide greater retention and stability
- Suitable for all printed circuit boards with the correct tin plating for press-in connectors
- Metal-plated hole with optimum diameter
  - 1.0 or 1.45<sup>+0.02</sup><sub>-0.06</sub> mm (HAL Sn)
  - 1.0 or 1.45<sup>+0.02</sup><sub>-0.06</sub> mm (Chem. Sn)
- Press-in pin for PCB thickness from 1.4 to 3 mm
- Press-in length of approx 3.2 mm
  - no unnecessary projection on underside of PCB
- Low press-in force required
  - reduces wear and tear on PCB and components
- High retention force within the PCB - doubles the values required by DIN EN 60352-5
- Robust bonded connection
- Excellent elastic spring behavior
- No deformation of the metal-plated end hole
- Length of contact area ≥ 1.3 mm
- No deformation of multilayer PCBs
- Minimal tin removal in the contact hole
  - reduces wear and tear on PCB and contact points

Pole No.	Item No.	Pack. Unit	Pole No.	Item No.	Pack. Unit
<b>Terminal strip, 1 press-in pin/pole, orange</b>			<b>Terminal strip, 1 press-in pin/pole, orange</b>		
3	739-153/100-000	280 (4 x 70)	3	739-233/100-000	220 (4 x 55)
4	739-154/100-000	220 (4 x 55)	4	739-234/100-000	160 (4 x 40)
5	739-155/100-000	160 (4 x 40)	5	739-235/100-000	120 (4 x 30)
6	739-156/100-000	140 (4 x 35)	6	739-236/100-000	100 (4 x 25)
7	739-157/100-000	120 (4 x 30)	7	739-237/100-000	80 (4 x 20)
8	739-158/100-000	100 (4 x 25)	8	739-238/100-000	80 (4 x 20)
9	739-159/100-000	100 (4 x 25)	9	739-239/100-000	60 (4 x 15)
10	739-160/100-000	80 (4 x 20)	10	739-240/100-000	60 (4 x 15)
12	739-162/100-000	60 (4 x 15)	12	739-242/100-000	40 (4 x 10)

# PCB Terminal Strips 1.5 mm<sup>2</sup> and 2.5 mm<sup>2</sup> Pin Spacing 3.5 mm, 3.81 mm, 5 mm, 5.08 mm, 7.5 mm, 7.62 mm 739 Series

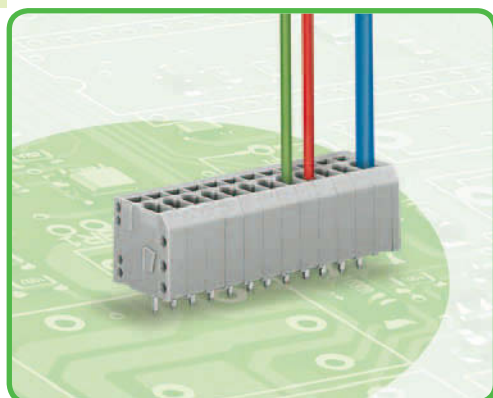

- Terminal strips with screwdriver-actuated CAGE CLAMP®
- Vertical conductor entry and conductor operation provide for space-saving positioning/grouping

### Technical data:

Pin Spacing	3.5 mm, 3.81 mm 0.138 in, 0.15 in			5 mm, 5.08 mm 0.197 in, 0.2 in			7.5 mm, 7.62 mm 0.295 in, 0.3 in			10 mm 0.394 in		
Rating per	IEC/EN 60664-1			IEC/EN 60664-1			IEC/EN 60664-1			IEC/EN 60664-1		
Overtoltage category	III	III	II	III	III	II	III	III	II	III	III	II
Pollution degree	3	2	2	3	2	2	3	2	2	3	2	2
Rated voltage				320 V	320 V	630 V	500 V	630 V	1000 V	500 V	630 V	1000 V
Rated surge voltage				4 kV	4 kV	4 kV	6 kV	6 kV	6 kV	6 kV	6 kV	6 kV
Rated voltage 3.5 mm	160 V	160 V	320 V									
Rated surge voltage 3.5 mm	2.5 kV	2.5 kV	2.5 kV									
Rated voltage 3.81 mm	200 V	320 V	500 V									
Rated surge voltage 3.81 mm	4 kV	4 kV	4 kV									
Nominal current	17,5 A	17,5 A	17,5 A	24 A	24 A	24 A	24 A	24 A	24 A	24 A	24 A	24 A
Approvals per	UL/CSA			UL/CSA			UL/CSA			UL/CSA		
Use group UL 1059	B	C	D	B	C	D	B	C	D	B	C	D
Rated voltage	300 V	-	300 V	300 V	-	300 V	300 V	-	300 V	300 V	-	300 V
Nominal current UL	6 A	-	6 A	12 A	-	10 A	12 A	-	10 A	12 A	-	10 A
Nominal current CSA	-	-	-	12 A	-	10 A	8 A	-	8 A	8 A	-	8 A

### Conductor and solder pin data for 3.5/3.81 mm pin spacing:

Connection technology	CAGE CLAMP®
Conductor size: solid	0.08 - 1.5 mm <sup>2</sup>
Conductor size: fine-stranded	0.08 - 1.5 mm <sup>2</sup>
Conductor size: fine-stranded	0.25 - 1.0 mm <sup>2</sup> (with insulated ferrule)
Conductor size: fine-stranded	0.25 - 1.5 mm <sup>2</sup> (with uninsulated ferrule)
AWG	28 - 14 (14: THHN, THWN)
Strip length	5 - 6 mm / 0.20 - 0.24 in
Conductor entry angle	90° to PCB
Solder pin: length/width	3.4 mm / 0.6 x 0.8 mm
Solder pin: drilled hole diameter	1.1 <sup>+0.1</sup> mm

### Conductor and solder pin data for 5/5.08 mm and 7.5/7.62 mm pin spacing:

Connection technology	CAGE CLAMP®
Conductor size: solid	0.08 - 2.5 mm <sup>2</sup>
Conductor size: fine-stranded	0.08 - 2.5 mm <sup>2</sup>
Conductor size: fine-stranded	0.25 - 1.5 mm <sup>2</sup> (with insulated ferrule)
Conductor size: fine-stranded	0.25 - 2.5 mm <sup>2</sup> (with uninsulated ferrule)
AWG	28 - 12 (12: THHN, THWN)
Strip length	8 - 9 mm / 0.31 - 0.35 in
Conductor entry angle	90° to PCB
Solder pin: length/width	3.2 mm / 0.8 x 1.2 mm
Solder pin: drilled hole diameter	1.6 <sup>+0.1</sup> mm

### Material data:

Material group	I
Insulating material	Nylon 6.6 (PA 6.6)
Flammability rating per UL 94	V0
Lower/Upper temperature limit	-60°C / +105°C
Clamping spring material	Chrome-nickel spring steel (CrNi)
Contact material	Electrolytic copper (E <sub>Cu</sub> )
Contact plating	tin-plated

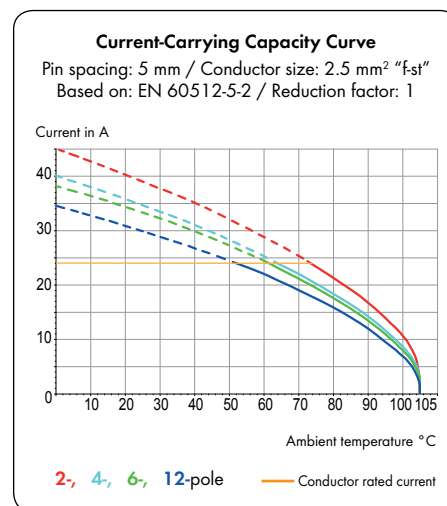

Current-Carrying Capacity Curve for 3,5 mm and 3,81 mm, see [www.wago.com](http://www.wago.com)

### 739 Series accessories:

Page:

Marking accessories	540 - 543
Operating tools	526 - 528
Screws	546

Pin spacing 3.5 mm / 0.138 in		With fixing flanges Pin spacing 3.5 mm / 0.138 in		Pin spacing 5 mm / 0.197 in	
0.08 - 1.5 mm <sup>2</sup> 160 V/2.5 kV/2 17.5 A	AWG 28 - 14 300 V/6 A	0.08 - 1.5 mm <sup>2</sup> 160 V/2.5 kV/2 17.5 A	AWG 28 - 14 300 V/6 A	0.08 - 2.5 mm <sup>2</sup> 320 V/4 kV/2 24 A	AWG 28 - 12 300 V/10 A

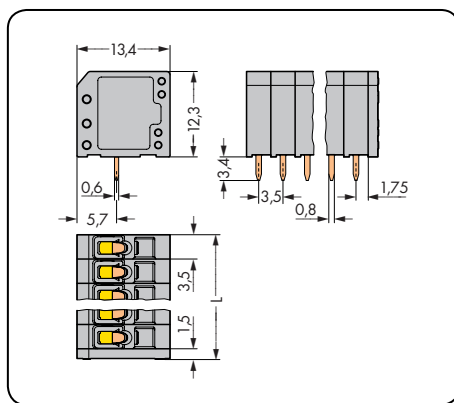

$$L = (\text{pole no.} \times \text{pin spacing}) + 1.5 \text{ mm}$$

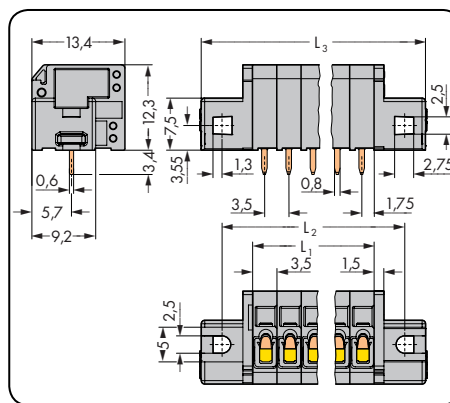

$$L_1 = \text{pole no.} \times \text{pin spacing}$$

$$L_2 = L_1 + 8.8 \text{ mm}$$

$$L_3 = L_1 + 14.8 \text{ mm}$$

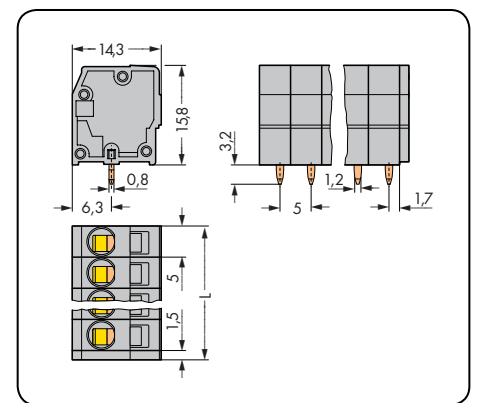

$$L = (\text{pole no.} - 1) \times \text{pin spacing} + 5 \text{ mm} + 1.5 \text{ mm}$$

Pole No.	Item No.	Pack. Unit	Pole No.	Item No.	Pack. Unit	Pole No.	Item No.	Pack. Unit
<b>Terminal strip, 1 solder pin/pole, gray</b>			<b>Terminal strip with fixing flanges, 1 solder pin/pole, gray</b>			<b>Terminal strip, 1 solder pin/pole, gray</b>		
2	739-302	560 (4 x 140)	2	739-302/001-000	220 (4 x 55)	2	739-102	400 (4 x 100)
3	739-303	400 (4 x 100)	3	739-303/001-000	180 (4 x 45)	3	739-103	280 (4 x 70)
4	739-304	300 (4 x 75)	4	739-304/001-000	160 (4 x 40)	4	739-104	220 (4 x 55)
5	739-305	240 (4 x 60)	5	739-305/001-000	140 (4 x 35)	5	739-105	180 (4 x 45)
6	739-306	200 (4 x 50)	6	739-306/001-000	120 (4 x 30)	6	739-106	140 (4 x 35)
7	739-307	180 (4 x 45)	7	739-307/001-000	120 (4 x 30)	7	739-107	120 (4 x 30)
8	739-308	160 (4 x 40)	8	739-308/001-000	100 (4 x 25)	8	739-108	100 (4 x 25)
9	739-309	140 (4 x 35)	9	739-309/001-000	100 (4 x 25)	9	739-109	100 (4 x 25)
10	739-310	120 (4 x 30)	10	739-310/001-000	80 (4 x 20)	10	739-110	80 (4 x 20)
12	739-312	100 (4 x 25)	12	739-312/001-000	80 (4 x 20)	12	739-112	60 (4 x 15)
						16	739-116	40 (4 x 10)
						24	739-124	20 (4 x 5)

**Item No. Suffixes:**  
**Colored Terminal Strips, 5 mm Pin Spacing:**

- black . . . . . /000-004
- red . . . . . /000-005
- blue . . . . . /000-006
- brown . . . . . /000-014
- light green . . . . . /000-017
- green . . . . . /000-023

**Ordering example:**  
 Terminal strip, 5 mm pin spacing  
 8-pole, brown: **739-108/000-014**

**(Production and prices depend on quantity required)**

# PCB Terminal Strips 1.5 mm<sup>2</sup> and 2.5 mm<sup>2</sup>

Pin spacing 7.5 mm / 0.295 in		Pin spacing 10 mm / 0.394 in		Pin spacing 3.81 mm / 0.15 in	
0.08 - 2.5 mm <sup>2</sup> 630 V/6 kV/2 24 A	AWG 28 - 12 300 V/10 A	0,08 - 1,5 mm <sup>2</sup> 320 V/4 kV/2 17,5 A	AWG 28 - 14 300 V/6 A	0.08 - 1.5 mm <sup>2</sup> 320 V/4 kV/2 17.5 A	AWG 28 - 14 300 V/6 A

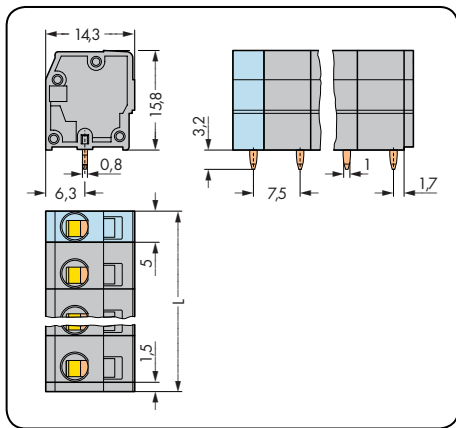
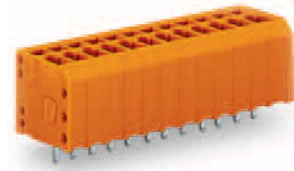
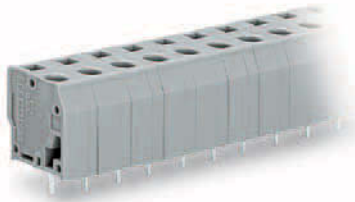

L = (pole no. - 1) x pin spacing + 5 mm + 1.5 mm

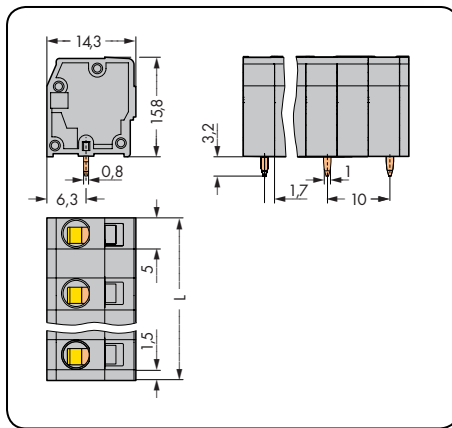

L = (pole no. - 1) x pin spacing + 5 mm + 1.5 mm

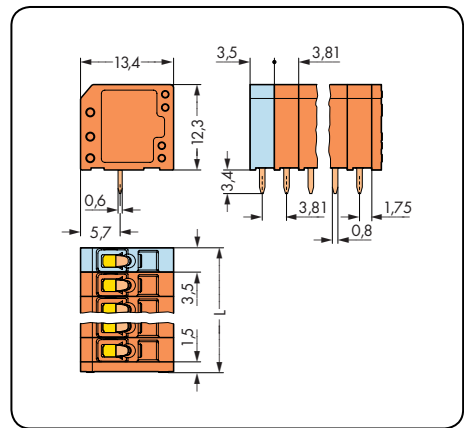

L = (pole no. - 1) x pin spacing + 3.5 mm + 1.5 mm

Pole No.	Item No.	Pack. Unit	Pole No.	Item No.	Pack. Unit	Pole No.	Item No.	Pack. Unit
Terminal strip, 1 solder pin/pole, gray			Terminal strip, 1 solder pin/pole, gray			Terminal strip, 1 solder pin/pole, orange		
2	739-202	340 (4 x 85)	2	739-3202	520 (4 x 130)	2	739-332	520 (4 x 130)
3	739-203	220 (4 x 55)	3	739-3203	360 (4 x 90)	3	739-333	360 (4 x 90)
4	739-204	160 (4 x 40)	4	739-3204	280 (4 x 70)	4	739-334	280 (4 x 70)
5	739-205	120 (4 x 30)	5	739-3205	220 (4 x 55)	5	739-335	220 (4 x 55)
6	739-206	100 (4 x 25)	6	739-3206	180 (4 x 45)	6	739-336	180 (4 x 45)
7	739-207	80 (4 x 20)	7	739-3207	160 (4 x 40)	7	739-337	160 (4 x 40)
8	739-208	80 (4 x 20)	8	739-3208	140 (4 x 35)	8	739-338	140 (4 x 35)
9	739-209	60 (4 x 15)	9	739-3209	120 (4 x 30)	9	739-339	120 (4 x 30)
10	739-210	60 (4 x 15)	10	739-3210	120 (4 x 30)	10	739-340	120 (4 x 30)
12	739-212	40 (4 x 10)	11	739-3211	100 (4 x 25)	12	739-342	100 (4 x 25)
			12	739-3212	100 (4 x 25)			

with fixing flanges Pin spacing 3.81 mm / 0.15 in		Pin spacing 5.08 mm / 0.2 in		Pin spacing 7.62 mm / 0.3 in	
0.08 - 1.5 mm <sup>2</sup> 320 V/4 kV/2 17.5 A	AWG 28 - 14 300 V/6 A	0.08 - 2.5 mm <sup>2</sup> 320 V/4 kV/2 24 A	AWG 28 - 12 300 V/10 A	0.08 - 2.5 mm <sup>2</sup> 630 V/6 kV/2 24 A	AWG 28 - 12 300 V/10 A

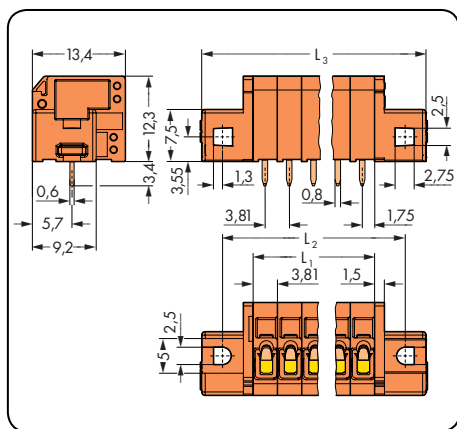

$L_1$  = pole no. x pin spacing  
 $L_2$  =  $L_1$  + 8.8 mm  
 $L_3$  =  $L_1$  + 14.8 mm

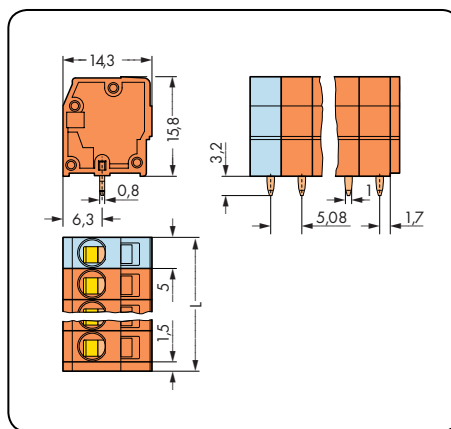

$L$  = (pole no. - 1) x pin spacing + 5 mm + 1.5 mm

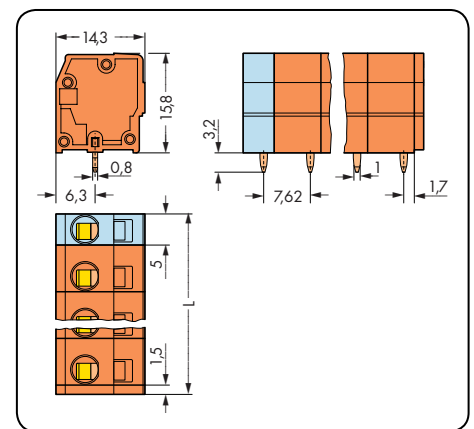

$L$  = (pole no. - 1) x pin spacing + 5 mm + 1.5 mm

Pole No.	Item No.	Pack. Unit	Pole No.	Item No.	Pack. Unit	Pole No.	Item No.	Pack. Unit
<b>Terminal strip with fixing flanges, 1 solder pin/pole, orange,</b>			<b>Terminal strip, 1 solder pin/pole, orange</b>			<b>Terminal strip, 1 solder pin/pole, orange</b>		
2	739-332/001-000	200 (4 x 50)	2	739-152	400 (4 x 100)	2	739-232	340 (4 x 85)
3	739-333/001-000	180 (4 x 45)	3	739-153	280 (4 x 70)	3	739-233	220 (4 x 55)
4	739-334/001-000	160 (4 x 40)	4	739-154	220 (4 x 55)	4	739-234	160 (4 x 40)
5	739-335/001-000	140 (4 x 35)	5	739-155	160 (4 x 40)	5	739-235	120 (4 x 30)
6	739-336/001-000	120 (4 x 30)	6	739-156	140 (4 x 35)	6	739-236	100 (4 x 25)
7	739-337/001-000	100 (4 x 25)	7	739-157	120 (4 x 30)	7	739-237	80 (4 x 20)
8	739-338/001-000	100 (4 x 25)	8	739-158	100 (4 x 25)	8	739-238	80 (4 x 20)
9	739-339/001-000	80 (4 x 20)	9	739-159	100 (4 x 25)	9	739-239	60 (4 x 15)
10	739-340/001-000	80 (4 x 20)	10	739-160	80 (4 x 20)	10	739-240	60 (4 x 15)
12	739-342/001-000	60 (4 x 15)	12	739-162	60 (4 x 15)	12	739-242	40 (4 x 10)
			16	739-166	40 (4 x 10)			
			24	739-174	20 (4 x 5)			



# PCB Terminal Strips 2.5 mm<sup>2</sup> Pin Spacing 5 mm 740 Series

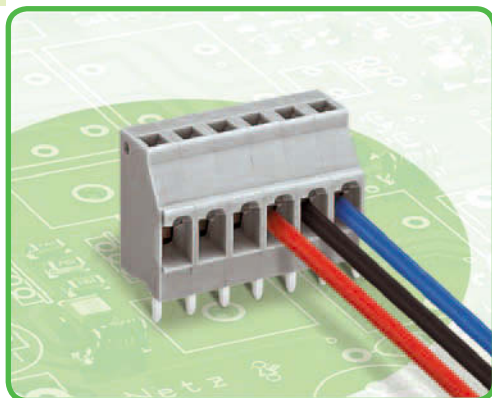

- Terminal strips with screwdriver-actuated CAGE CLAMP® connection
- Top-of-unit actuation, side-entry termination
- Pin and dimensions compatible with screw-type terminal blocks of similar design
- Terminal strips may be positioned adjacently without losing any poles

#### Technical data:

Pin Spacing	5 mm 0.197 in				
Rating per	IEC/EN 60664-1				
Overvoltage category	III	III	II		
Pollution degree	3	2	2		
Rated voltage	300 V	320 V	630 V		
Rated surge voltage	4 kV	4 kV	4 kV		
Nominal current	16 A	16 A	16 A		
Approvals per	UL/CSA				
Use group UL 1059	B	C	D		
Rated voltage	300 V	-	300 V		
Nominal current UL	10 A	-	10 A		
Nominal current CSA	16 A	-	10 A		

#### Conductor and solder pin data:

Connection technology	CAGE CLAMP®
Conductor size: solid	0.08 - 2.5 mm <sup>2</sup>
Conductor size: fine-stranded	0.08 - 2.5 mm <sup>2</sup>
Conductor size: fine-stranded	0.25 - 1.5 mm <sup>2</sup> (with insulated ferrule)
Conductor size: fine-stranded	0.25 - 1.5 mm <sup>2</sup> (with uninsulated ferrule)
AWG	28 - 12 (12: THHN, THWN)
Strip length	6 - 7 mm / 0.24 - 0.28 in
Conductor entry angle	0° to PCB
Solder pin: length/width	5.1 mm / 0.8 x 1 mm
Solder pin: drilled hole diameter	1.3 <sup>+0.1</sup> mm

#### Material data:

Material group	I
Insulating material	Nylon 6.6 (PA 6.6)
Flammability rating per UL 94	V0
Lower/Upper temperature limit	-60°C / +105°C
Clamping spring material	Chrome-nickel spring steel (CrNi)
Contact material	Electrolytic copper (E <sub>cu</sub> )
Contact plating	tin-plated

#### 740 Series accessories:

#### Page:

Marking accessories	540 - 543
Operating tools	526 - 528

Pin spacing 5 mm / 0.197 in

0.08 - 2.5 mm <sup>2</sup>	AWG 28 - 12
320 V/4 kV/2 16 A	300 V/10 A

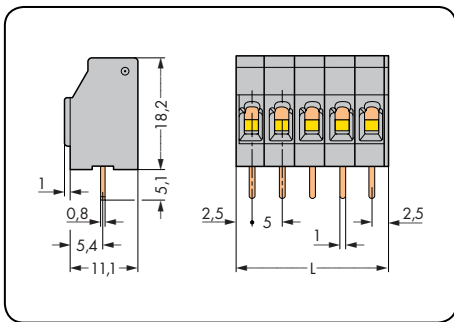
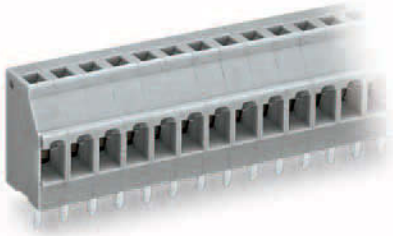

L = pole no. x pin spacing

Pole No.	Item No.	Pack. Unit	Item No. Suffixes: Colored Terminal Strips, 5 mm Pin Spacing
<b>Terminal strip, 1 solder pin/pole, gray</b>			
2	740-102	460 (4 x 115)	● black ...-.../000-004
3	740-103	300 (4 x 75)	● blue ...-.../000-006
4	740-104	240 (4 x 60)	○ light gray Δ RAL 7035 ...-.../000-021
5	740-105	180 (4 x 45)	● green ...-.../000-023
6	740-106	140 (4 x 35)	
7	740-107	120 (4 x 30)	<b>Ordering example:</b>
8	740-108	100 (4 x 25)	Terminal strip, 5 mm pin spacing,
9	740-109	100 (4 x 25)	12-pole, green: <b>740-112/000-023</b>
10	740-110	80 (4 x 20)	
12	740-112	60 (4 x 15)	
16	740-116	60 (4 x 15)	
24	740-124	40 (4 x 10)	<b>(Production and prices depend on quantity required)</b>

