

Measuring current transformers WS50x80S...WS80x160S

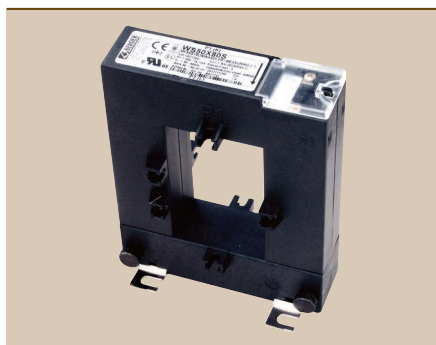

Measuring current transformers of the WS50x80S...WS80x160S series, split-core type



Measuring current transformers WS50x80S



Measuring current transformers WS80x160S

Product description

The highly sensitive split-core-type WS... series measuring current transformers convert residual currents of 10 mA... 100 A into evaluable RCM or EDS signals and can be retrofitted to existing electrical installations where disconnection must be prevented. The CTs are connected to the respective evaluator by two wires. Depending on the connecting lead used, the distance between the CT and the evaluator may be up to 40 m.

Make sure that all live conductors are routed through the measuring current transformer and that these conductors are not shielded.

Never route a PE conductor through the measuring current transformer!

Application

- For residual current monitors (RCM)
- For residual current monitoring systems (RCMS)

Standards

WS... measuring current transformers comply with the device standards: DIN EN 60044-1, IEC 60044-1

Approvals



Ordering information

Internal dimensions	Type	Art. No.
50 x 80 mm	WS50x80S	B 911 741
80 x 80 mm	WS80x80S	B 911 742
80 x 120 mm	WS80x120S	B 911 743
80 x 160 mm	WS80x160S	B 911 755

Approvals

Type	UL	GL
WS50x80S	■	■
WS80x80S	■	■
WS80x120S	■	■
WS80x160S	–	–

Technical data
Insulation coordination acc. to IEC 60044-1

Highest system voltage for electrical equipment U_m	AC 720 V
Rated impulse withstand voltage U_{isol}	3 kV

Measuring circuit

Rated transformation ratio	600/1
Rated burden	180 Ω
Rated primary current	≤ 10 A (100 A)
Rated primary current	≥ 10 mA
Nominal power	50 mVA
Rated frequency	50...400 Hz
Internal resistance	5...8 Ω
Secondary overvoltage protection	with suppressor diode P6KE6V8CP
Accuracy class	5
Rated continuous thermal current	100 A
Rated short-time thermal current	14 kA/1 s
Rated dynamic current	35 kA/30 ms

Environment

Standard	IEC 60044-1
Shock resistance IEC 60068-2-27 (device in operation)	15 g/11 ms
Bumping IEC 60068-2-29 (transport)	40 g/6 s
Vibration resistance IEC 60068-2-6 (device in operation)	1 g/10...150 Hz
Vibration resistance IEC 60068-2-6 (transport)	2 g/10...150 Hz
Ambient temperature (during operation)	-10...+50 °C
Storage temperature range	-40...+70 °C
Climatic class acc. to DIN IEC 60721-3-3	3K5

Connection

Connection	screw-type terminals
Connection	
rigid/flexible	0.2...4/0.2...2.5 mm ²
flexible with ferrules with/without plastic sleeve	0.25...2.5 mm ²
Conductor sizes (AWG)	24...12
Connection to the evaluator	
single wire ≥ 0.75 mm ²	0...1 m
single wire, twisted ≥ 0.75 mm ²	0...10 m
shielded cable ≥ 0.6 mm ²	0...40 m
Shielded cable (shield on one side connected to PE)	recommended: J-Y(St)Y min. 2 x 0.6

Other

Operating mode	continuous operation
Mounting	any position
Degree of protection, internal components (DIN EN 60529)	IP40
Degree of protection, terminals (DIN EN 60529)	IP20
Screw mounting	M5
Flammability class	UL94 V-0
Operating manual	TBP409005

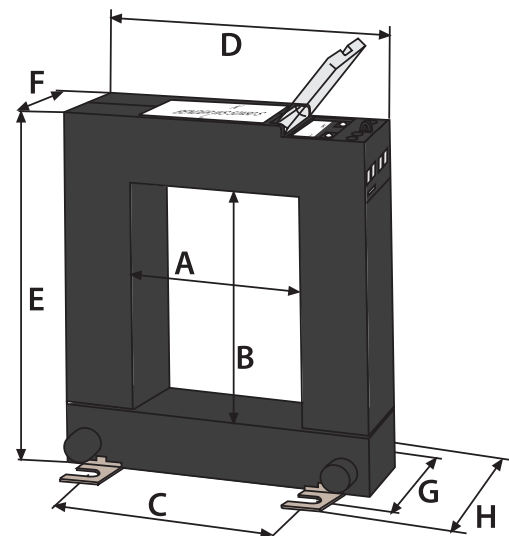
Dimensions (mm) and weights (g)

Type WS50x80S...WS80x120S

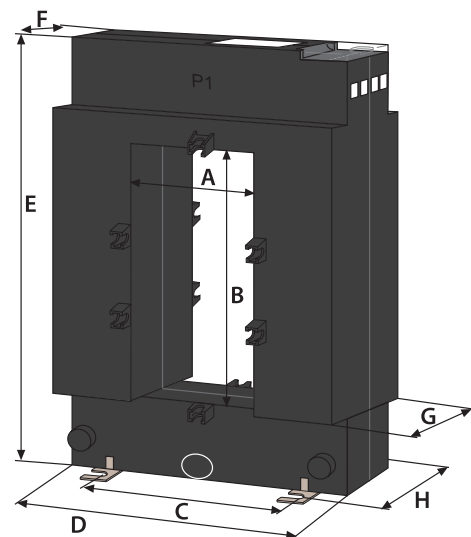

Type WS80x160S

Type	Dimensions (mm)								Weight
	A	B	C	D	E	F	G	H	
WS50x80S	50	80	78	114	145	32	45	59	900 g
WS80x80S	80	80	108	144	145	32	45	59	1050 g
WS80x120S	80	120	108	144	185	32	45	59	1250 g
WS80x160S	80	160	120	184	225	32	52	59	2550 g

Installation instructions

- Do not pass shielded cables through the measuring current transformer.
- As a general principle, the PE conductor and low-resistance conductor loops must not be passed through the measuring current transformer!

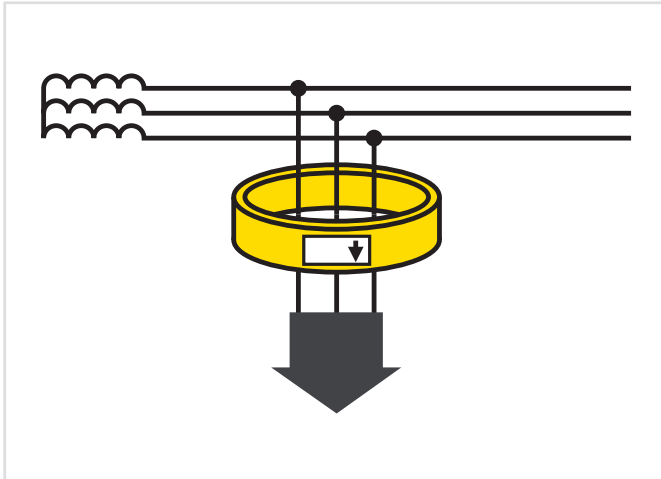

It is important that the leads are passed through the measuring current transformer in the right direction

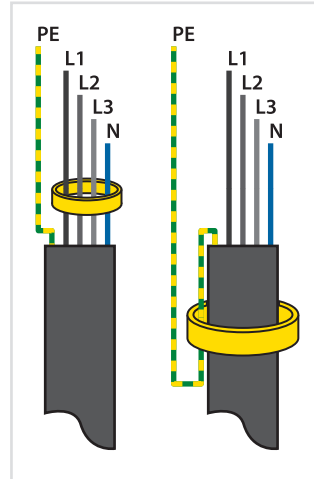

Never pass a PE conductor through the measuring current transformer

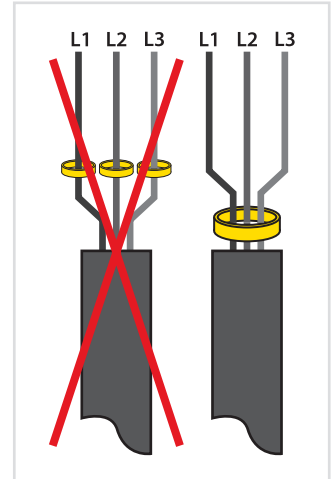

Make sure that all current-carrying leads are passed through the measuring current transformer

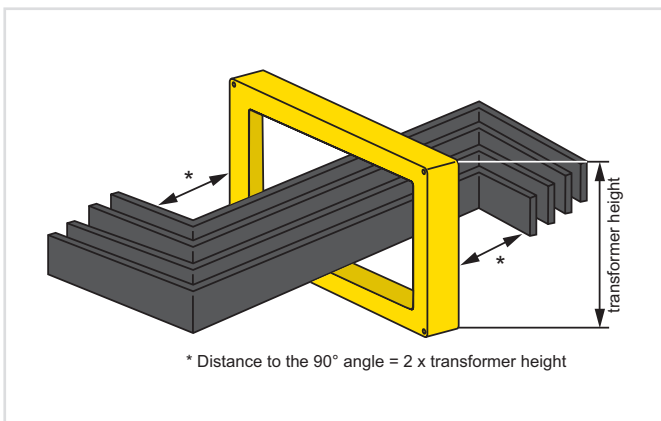

Bending a lead is only permissible with a certain distance to the current transformer

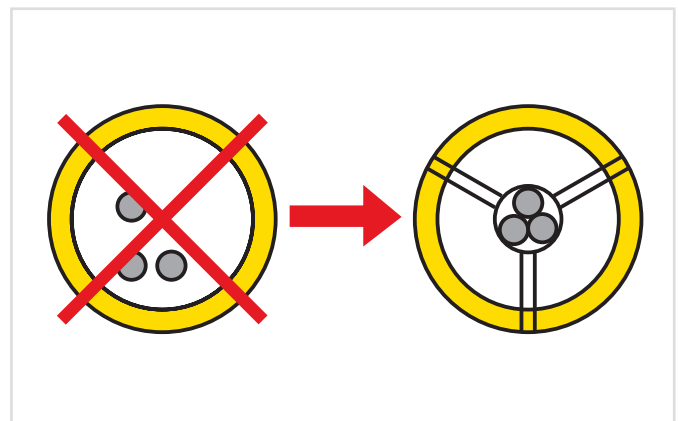

The leads must be aligned with the centre of the measuring current transformer



Bender GmbH & Co. KG

P.O. Box 1161 • 35301 Gruenberg • Germany
 Londorfer Strasse 65 • 35305 Gruenberg • Germany
 Tel.: +49 6401 807-0 • Fax: +49 6401 807-259
 E-Mail: info@bender.de • www.bender.de



BENDER Group