

# ISOMETER® isoNAV685-D-B

Insulation monitoring device for offline monitoring of de-energised loads

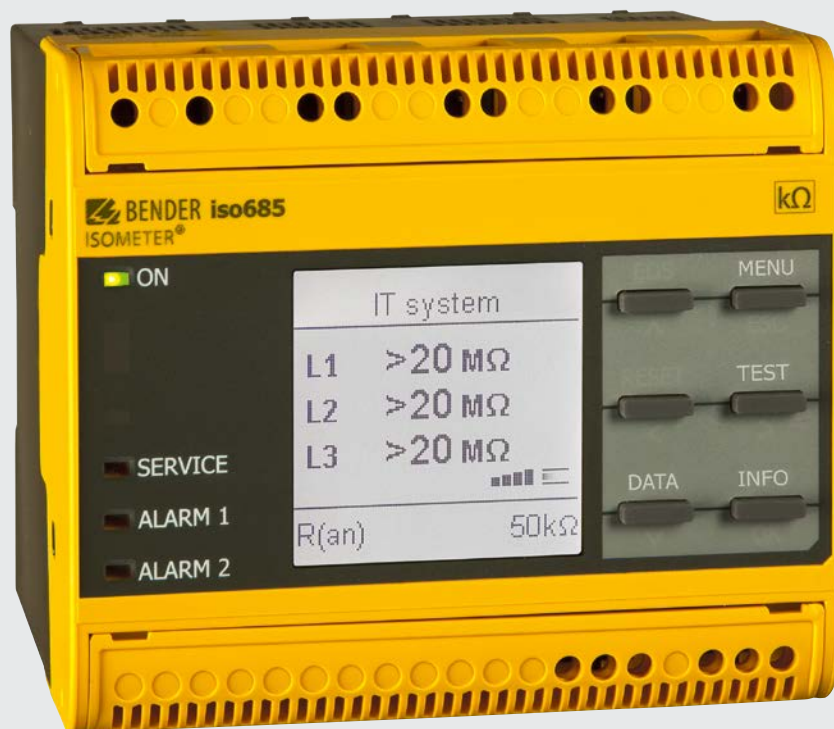



ISOMETER® isoNAV685-D-B

### Device features

- ISOMETER® to monitor the insulation resistance in de-energised systems.
- Automatic adaptation to the existing system leakage capacitance.
- **AMP<sup>Plus</sup>** measurement method
- An adjustable response value in the range 10 kΩ...1 MΩ (factory setting = 50 kΩ).
- High-resolution graphic LC display for excellent readability and recording of the device status.
- Earth connection monitoring.
- Automatic device self test.
- Graphical representation of the insulation resistance over time (isoGraph)
- History memory with real-time clock (buffer for three days) for storing 1023 alarm messages with date and time.
- Freely programmable digital inputs and outputs.
- Remote setting via the Internet or Intranet (Webserver/Option: COMTRAXX® Gateway).
- Worldwide remote diagnosis via the Internet.
- BCOM, Modbus TCP and web server.

### Product description

The ISOMETER® isoNAV685-D-B is an insulation monitoring device for IT systems in accordance with IEC 61557-8. It is universally applicable in de-energised TN, TT or IT systems.

### Application

- Monitoring of de-energised loads and systems

### Function

The insulation monitoring device ISOMETER® isoNAV685-D-B monitors the entire insulation resistance of systems that are switched off and triggers an alarm when the insulation resistance value falls below a preset response value.

The insulation resistance of the L1, L2 and L3 coupling paths is measured sequentially. This means that faults are not only measured, but they can also be localized or located. The test time may vary, e.g. it may be longer, depending on the leakage capacitance.

To obtain a measurement the device has to be connected between the IT system (unearthed system) and the protective earth conductor (PE). A measuring current in the  $\mu\text{A}$  range is superimposed onto the system which is recorded and evaluated by a micro-controlled measuring circuit. The measuring time is dependent on the selected measurement profiles, the system leakage capacitance, the insulation resistance and possible system-related disturbances.

The response values and other parameters are set using a commissioning wizard as well as via different setup menus using the device buttons and a high-resolution graphical LC display. The selected settings are stored in a permanent fail-safe memory. Different languages can be selected for the setup menus as well as the messages indicated on the display. The device utilises a clock for storing fault messages and events in a history memory with time and date stamp. The settings can be protected against unauthorised modifications by entering a password. To ensure proper functioning of connection monitoring, the device requires the setting of the system type 3AC and the prescribed wiring of the appropriate terminals L1/+, L2, L3/-.

The insulation monitoring device is able to measure the insulation resistance reliably and precisely in all common IT systems (unearthed systems). Due to various applications, system types, operating conditions, application of variable-speed drives, high system leakage capacitances etc., the measurement technique must be able to meet varying requirements in order to ensure an optimised response time and relative uncertainty. Different measurement profiles which can be selected from a setup menu allow optimum adaptation of the measurement technique to the specific application.

If the resistance value below a set response value  $R_{an}$ , the associated alarm relay is activated, the LED ALARM 1 (alarm at L1 or L2) or ALARM 2 (alarm at L3) lights and the LCD shows the measured value. If the fault memory is activated, the fault message will be stored. Pressing the RESET button resets the insulation fault message, provided that the current insulation resistance displayed at the time of resetting is at least 25 % above the actual response value. As additional information, the quality of the measuring signal and the time required to update the measured value are shown on the display.

### Interfaces

- Communication protocol Modbus TCP
- BCOM for Bender device communication via Ethernet
- Integrated web server for reading out measured values and for parameter setting

### Measurement method

**AMPPlus** The isoNAV685 series uses the patented **AMPPlus** measurement method. This measurement method allows concise monitoring of modern power supply systems, also in case of extensive, directly connected DC components and high system leakage capacitances.

### Standards

The ISOMETER® has been developed in compliance with the following standards:

- DIN EN 61557-8 (VDE 0413-8):2015-12
- IEC 61557-8:2014-12
- IEC 61557-8:2014/COR1:2016
- DIN EN 61557-8 Ber 1 (VDE 0413-8 Ber 1):2016-12

### Certifications



### Operating elements

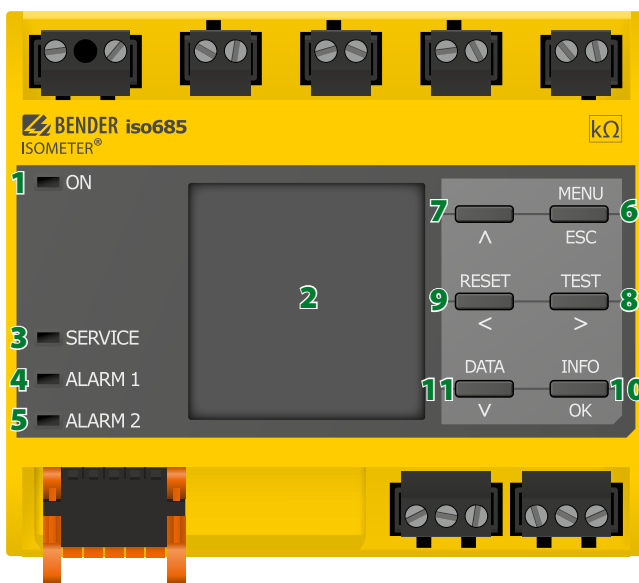

- 1 - The LED "ON" lights when the device is turned on.
- 2 - The device display shows information regarding the device and the measurements.
- 3 - The LED "SERVICE" lights when there is either a device fault or a connection fault, or when the device is in maintenance mode.
- 4 - The LED "ALARM 1" lights when the insulation resistance of the IT system falls below the set response value  $R_{an1}$ .
- 5 - The LED "ALARM 2" lights when the insulation resistance of the IT system falls below the set response value  $R_{an2}$ .
- 6 - "MENU" button: Opens the device menu.  
"ESC" button: Cancels the current process or navigates one step back in the device menu.
- 7 - "Λ" button: Navigates up in a list or increases a value.
- 8 - "TEST" button: Starts the device self test.  
">" button: Navigates forwards (e.g. to the next setting step) or selects a parameter.
- 9 - "RESET" button: Resets alarms.  
"<" button: Navigates backwards (e.g. to the previous setting step) or selects a parameter.
- 10 - "Info" button: Shows information.  
"OK" button: Confirms an action or a selection.
- 11 - "DATA" button: Indicates data and values.  
"V" button: Navigates down in a list or reduces a value.

**Wiring diagram**

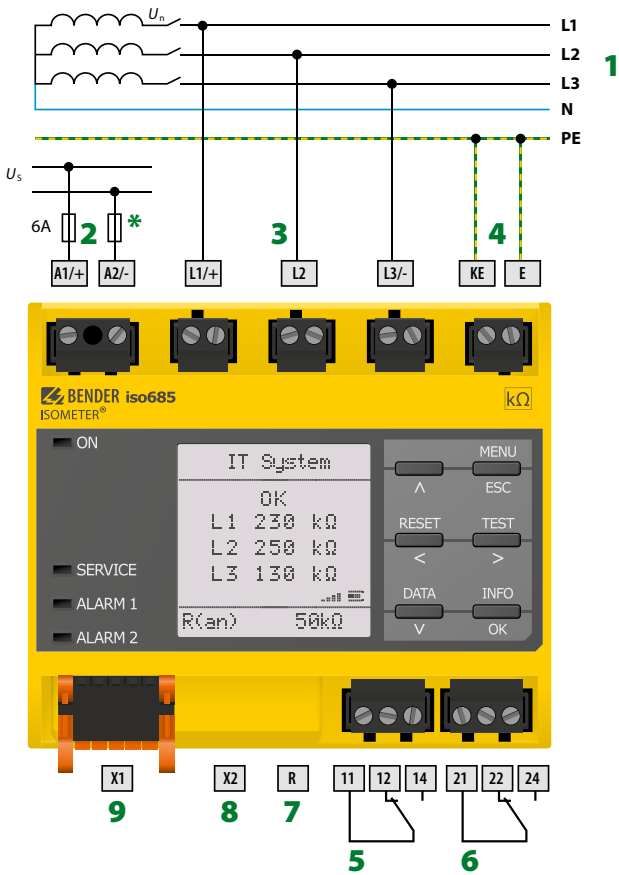

- 1 - Connection to a 3(N)AC system
- 2 - Supply voltage  $U_s$  (see nameplate) via 6 A fuse
- 3 - Connection to the IT system to be monitored (L1/+, L2, L3/-)
- 4 - Separate connection of KE, E to PE
- 5 - (K1) Alarm relay 1, available changeover contacts
- 6 - (K2) Alarm relay 2, available changeover contacts
- 7 - Switchable resistor R for RS-485 bus termination
- 8 - Ethernet interface
- 9 - Digital interface
- \* - 6 A fuse for systems > 690 V

**Note:**  
 According to DIN VDE 0100-430, devices for protection against a short-circuit can be omitted for the coupling of terminals L1/+, L2, L3/- to the IT system  $\leq 690$  V to be monitored if the wiring is carried out in such a manner as to reduce the risk of a short-circuit to a minimum. (Recommendation: Ensure short-circuit-proof and earth-fault-proof wiring).

The connecting lines L1/+, L2, L3/- to the system to be monitored must be carried out as spur lines. No load current may be conducted through the terminals.

**For UL applications:**

Use 60/70°C copper lines only!  
 UL and CSA applications require the supply voltage to be protected via 5 A fuses.

Connection to frequency inverters for monitoring in offline mode

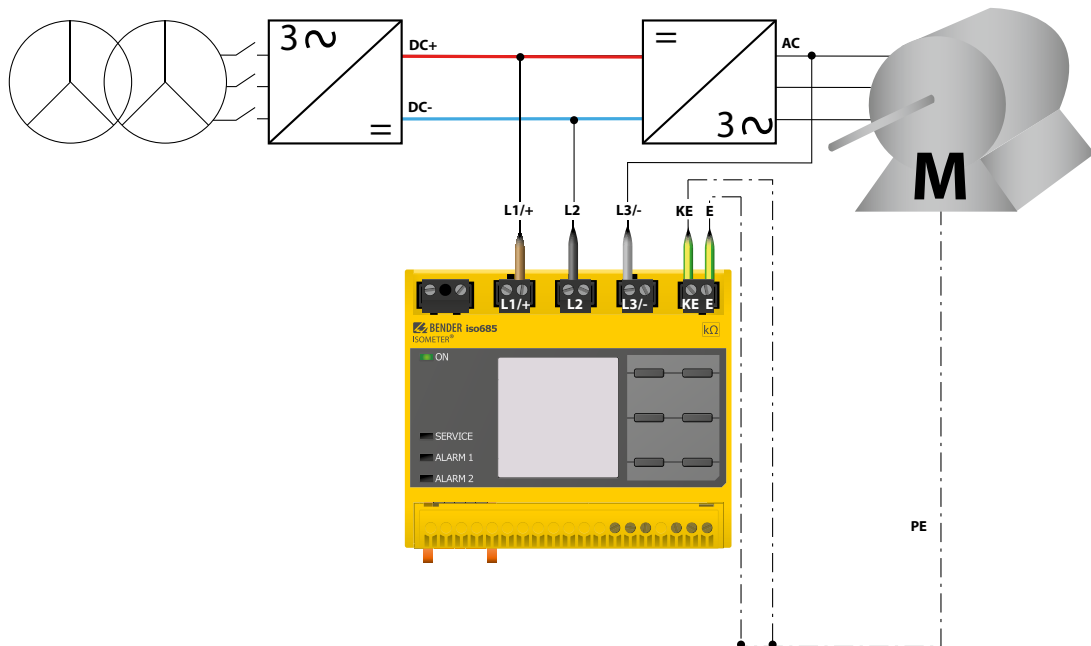

Digital interface X1

Digital interface	Terminal	Colour
<p>X1</p>	I1	Input 1
	I2	Input 2
	I3	Input 3
	A	RS-485 A
	B	RS-485 B
	+	+24V
	Q1	Output 1
	Q2	Output 2
	M+	not used
	⊥	Ground

Digital outputs

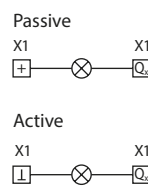

Digital inputs

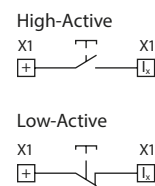

Analogue output

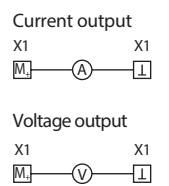

Example

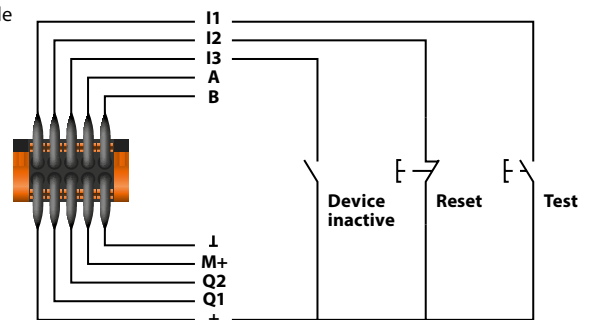

Connection to X1



Caution

**Danger of damage to property due to faulty connections!**  
The device can be damaged if the unit is simultaneously connected to the supply voltage via the X1 interface and via A1/+, A2/-. Do not connect the device simultaneously via X1 and A1/+, A2/- to different supply voltages.



Caution

**Danger of damage to property due to incorrect nominal voltage!**  
When the device is powered via the X1 interface, the nominal voltage must be 24 V otherwise the unit may be damaged. Connect to the X1 interface with a nominal voltage of 24 V only.

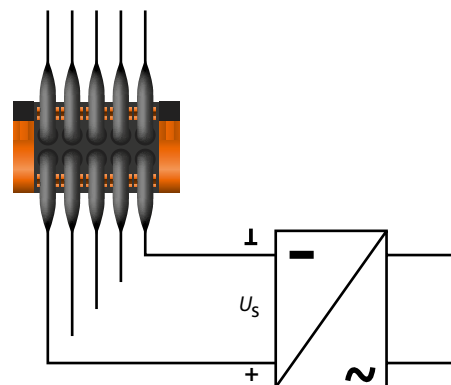

## Technical data

### Insulation coordination according to IEC 60664-1/IEC 60664-3

Definitions:	
Measuring circuit (IC1)	(L1/+, L2, L3/-)
Supply circuit (IC2)	A1, A2
Output circuit 1 (IC3)	11, 12, 14
Output circuit 2 (IC4)	21, 22, 24
Control circuit (IC5)	(E, KE), (X1, ETH, X3, X4)
Rated voltage	1000 V
Overvoltage category	III
Rated impulse voltage:	
IC1/(IC2-5)	8 kV
IC2/(IC3-5)	4 kV
IC3/(IC4-5)	4 kV
IC4/IC5	4 kV
Rated insulation voltage:	
IC1/(IC2-5)	1000 V
IC2/(IC3-5)	250 V
IC3/(IC4-5)	250 V
IC4/IC5	250 V
Pollution degree for accessible parts on the outside of the device housing ( $U_n < 690$ V)	3
Pollution degree for accessible parts on the outside of the device housing ( $U_n > 690 < 1000$ V)	2
Protective separation (reinforced insulation) between:	
IC1/(IC2-5)	Overvoltage category III, 1000 V
IC2/(IC3-5)	Overvoltage category III, 300 V
IC3/(IC4-5)	Overvoltage category III, 300 V
IC4/IC5	Overvoltage category III, 300 V
Voltage test (routine test) according to IEC 61010-1:	
IC2/(IC3-5)	AC 2,2 kV
IC3/(IC4-5)	AC 2,2 kV
IC4/IC5	AC 2,2 kV

### Supply voltage

#### Supply via A1/+, A2/-:

Supply voltage range $U_s$	AC/DC 24...240 V
Tolerance of $U_s$	-30...+15%
Maximum permissible input current of $U_s$	650 mA
Frequency range of $U_s$	DC, 50...400 Hz <sup>1)</sup>
Tolerance of the frequency range of $U_s$	-5...+15%
Power consumption, typically 50/60 Hz	≤ 12 W/21 VA
Power consumption, typically 400 Hz	≤ 12 W/45 VA

#### Supply via X1:

Supply voltage $U_s$	DC 24 V
Tolerance of $U_s$	DC -20...+25 %

### IT system being monitored

Nominal system voltage range $U_n$	offline
Circuit capacity internal mains switch	AC 0...690 V DC 0...1000 V AC/DC 0...600 V (for UL applications)

### Response values

Response value $R_{an1}$ (alarm 1)	1 kΩ...10 MΩ
Response value $R_{an2}$ (alarm 2)	1 kΩ...10 MΩ
Relative uncertainty (acc. to IEC 61557-8)	profile dependent, ±15 %, at least ±1 kΩ
Hysteresis	25 %, at least 1 kΩ

### Time response

Response time $t_{an}$ at $R_f = 0.5 \times R_{an}$ ( $R_{an} = 10$ kΩ) and $C_e = 1$ μF according to IEC 61557-8	30 s
Start-up delay $T_{start-up}$	0...120 s

### Measuring circuit

Measuring voltage $U_m$	±5 V
Measuring current $I_m$	≤ 13,4 μA
Internal resistance $R_i, Z_i$	≥ 372 kΩ
Permissible extraneous DC voltage $U_{fg}$	≤ 1200 V
Permissible system leakage capacitance $C_e$	150 μF

### Display

Indication	graphic display 127 x 127 pixels, 40 x 40 mm <sup>2)</sup>
Display range measured value	0.1 kΩ...20 MΩ

### LEDs

ON (operation LED)	green
SERVICE	yellow
ALARM 1 (L1 and L2)	yellow
ALARM 2 (L3)	yellow

### In-/Outputs (X1-Interface)

Cable length X1 (unshielded cable)	≤ 10 m
Cable length X1 (shielded cable, shield connected to earth (PE) on one end, recommended: J-V(St)Y min. 2x0,8)	≤ 100 m
Total max. supply output current via X1./X1.GND for each output	max. 1 A
Total max. supply output current via A1/A2 on X1	max. 200 mA
Total max. supply output current via A1/A2 on X1 between 16,8 V and 40 V	$I_{LmaxX1} = 10mA + 7mA/V * U_s$ <sup>3)</sup> (negative values are not allowed for $I_{LmaxX1}$ )

### Digital Inputs (I1, I2, I3)

Number	3
Operating mode, adjustable	active high, active low
Functions	none, test, reset, device deactivated
Voltage:	Low DC -3...5 V, High DC 11...32 V
Tolerance Voltage	±10 %

### Digital Outputs (Q1, Q2)

Number	2
Operating mode, adjustable	active, passive
Functions	off, connection fault, Alarm L1, Alarm L2, Alarm L3, device fault, common alarm
Voltage	passive DC 0...32 V, active DC 0/19.2...32 V

### Interfaces

#### Field bus:

Interface/protocol	web server/Modbus TCP/BCOM
Data rate	10/100 Mbit/s, autodetect
Max. amount Modbus requests	< 100/s
Cable length	≤ 100 m
Connection	RJ45
IP address	DHCP/manual 192.168.0.5
Network mask	255.255.255.0
BCOM address	system-1-0
Function	communication interface

**Technical data (continuation)**
**Switching elements**

Number of switching elements	2 changeover contacts
Operating mode	N/C operation/N/O operation
Contact 11-12-14	off, connection fault, Alarm L1, Alarm L2, Alarm L3, device fault, common alarm
Contact 21-22-24	off, connection fault, Alarm L1, Alarm L2, Alarm L3, device fault, common alarm
Electrical endurance under rated operating conditions, number of cycles	10.000

**Contact data acc. to IEC 60947-5-1:**

Utilisation category	AC-13/AC-14/DC-12/DC-12
Rated operational voltage	230 V/230 V/24 V/110 V/220 V
Rated operational current	5 A/3 A/1 A/0.2 A/0.1 A
Rated insulation voltage ≤ 2000 m NN	250 V
Rated insulation voltage ≤ 3000 m NN	160 V
Minimum contact rating	1 mA at AC/DC ≥ 10 V

**Environment/EMC**

EMC	IEC 61326-2-4 <sup>4)</sup>
-----	-----------------------------

**Ambient temperatures:**

Operating temperature	-25...+55 °C
Transport	-40...+85 °C
Long-term storage	-40...+70 °C

**Classification of climatic conditions acc. to IEC 60721:**

Stationary use (IEC 60721-3-3)	3K5 (except condensation and formation of ice)
Transport (IEC 60721-3-2)	2K3
Long-term storage (IEC 60721-3-1)	1K4

**Classification of mechanical conditions acc. to IEC 60721:**

Stationary use (IEC 60721-3-3)	3M4
Transport (IEC 60721-3-2)	2M2
Long-term storage (IEC 60721-3-1)	1M3
Area of application	≤ 3000 m NN

**Connection**

Connection type	pluggable screw-type terminal or push-wire terminal
-----------------	---

**Screw-type terminals:**

Nominal current	≤ 10 A
Tightening torque	0.5...0.6 Nm (5...7 lb-in)
Conductor sizes	AWG 24-12
Stripping length	7 mm
rigid/flexible	0.2...2.5 mm <sup>2</sup>
flexible with ferrules, with/without plastic sleeve	0.25...2.5 mm <sup>2</sup>
Multiple conductor, rigid	0.2...1 mm <sup>2</sup>
Multiple conductor, flexible	0.2...1.5 mm <sup>2</sup>
Multiple conductor, flexible with ferrule without plastic sleeve	0.25...1 mm <sup>2</sup>
Multiple conductor, flexible with TWIN ferrule with plastic sleeve	0.5...1.5 mm <sup>2</sup>

**Push-wire terminals:**

Nominal current	≤ 10 A
Conductor sizes	AWG 24-12
Stripping length	10 mm
rigid/flexible	0.2...2.5 mm <sup>2</sup>
flexible with ferrules, with/without plastic sleeve	0.25...2.5 mm <sup>2</sup>
Multiple conductor, flexible with TWIN ferrule with plastic sleeve	0.5...1.5 mm <sup>2</sup>

**Push-wire terminals X1:**

Nominal current	≤ 8 A
Conductor sizes	AWG 24-16
Stripping length	10 mm
rigid/flexible	0.2...1.5 mm <sup>2</sup>
flexible with ferrule without plastic sleeve	0.25...1.5 mm <sup>2</sup>
flexible with TWIN ferrule with plastic sleeve	0.25...0.75 mm <sup>2</sup>

**Other**

Operating mode	continuous operation
Mounting (0°)	display oriented, cooling slots must be ventilated vertically <sup>5)</sup>
Degree of protection internal components	IP40
Degree of protection terminals	IP20
DIN rail mounting acc. to	IEC 60715
Screw fixing	3 x M4 with mounting clip
Enclosure material	polycarbonate
Flammability class	V-0
ANSI code	64
Dimensions (W x H x D)	108 x 93 x 110 mm
Weight	< 390 g

<sup>1)</sup> At a frequency > 200 Hz, the connection of X1 must be insulated. Only permanently installed devices which at least have overvoltage category CAT2 (300V) may be connected.

<sup>2)</sup> Indication limited outside the temperature range -25...+55 °C.

<sup>3)</sup>  $U_s$  [Volt] = supply voltage ISOMETER®

<sup>4)</sup> This is a class A product. In a domestic environment, this product may cause radio interference. In this case, the user may be required to take corrective actions.

<sup>5)</sup> Recommendation: Devices mounted at 0° (display-oriented, cooling slots must be ventilated vertically).

For devices mounted at an angle of 45°, the max. working temperature is reduced by 10 °C.

For devices mounted at an angle of 90°, the max. working temperature is reduced by 20 °C.

## Ordering information

Nominal system voltage range $U_n$	Supply voltage $U_s$		Type	Art. no.
	AC	DC		
offline	24...240 V; 50...400 Hz	24...240 V	isoNAV685-D-B 	B91067024

## Accessories

Description	Art. no.
A set of screw-type terminals <sup>1)</sup>	B91067901
A set of push-wire terminals	B91067902
Enclosure accessories (terminal cover, 2 mounting clips) <sup>1)</sup>	B91067903

<sup>1)</sup> included in the scope of delivery

## Dimension diagram

Dimensions in mm

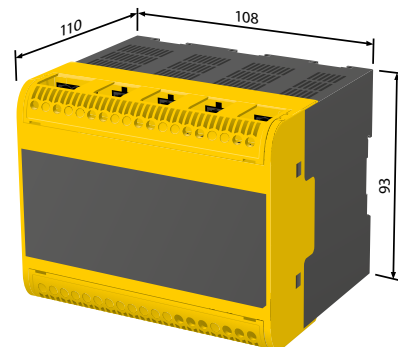

### Bender GmbH & Co. KG

P.O. Box 1161 • 35301 Gruenberg • Germany  
 Londorfer Straße 65 • 35305 Gruenberg • Germany  
 Tel.: +49 6401 807-0 • Fax: +49 6401 807-259  
 E-mail: info@bender.de • www.bender.de



BENDER Group