

ISOMETER® isoPV485

Insulation monitoring device for unearthed AC/DC IT systems
in small and medium-sized photovoltaic systems



ISOMETER® isoPV485

Insulation monitoring device for unearthed AC/DC IT systems
in small and medium-sized photovoltaic systems



ISOMETER® isoPV485

Device features

- Insulation monitoring for IT systems
AC 0...800 V, DC 0...1000 V, 42...460 Hz
- System leakage capacitance $\leq 100 \mu\text{F}$,
corresponds to a power generation capacity
of approx. 100 kW
- Combined LED
 - lights during normal operation
 - flashes in case of alarm or system fault
- Potential-free output
2...10 V = 2 k Ω ...1 M Ω for further
processing in SCADA systems
- Continuous self monitoring
- Test and reset button (external)
- 9-module enclosure (162 mm)

Product description

The ISOMETER® isoPV485 is designed for insulation monitoring in photovoltaic systems. It is used for monitoring the insulation resistance between the solar modules and the inverter to earth. The patented AMP measurement method allows insulation faults to be measured with the same sensitivity at all points in the system. Another advantage of this measurement method is that symmetrical faults, as for example caused by humidity and dirt, can also be detected.

Function

The condition of the insulation of the system to be monitored L1/L2 to earth is continuously determined and is available at the electrically isolated voltage output M+/M- as a signal that is proportional to the insulation value (2...10 V). If the value of the insulation resistance falls below 10 k Ω , the alarm relay switches (11, 12, 14) and the green alarm LED flashes (0.3 Hz). This signal can subsequently be forwarded to SCADA systems where it is processed accordingly to be available as information.

Both the device function and the connections to earth are continuously monitored. If a fault occurs, the voltage level at M+/M- increases to 1 V. The green alarm LED flashes (2 Hz). The device function can be tested using the optional external test button.

Measurement method

The isoPV485 series uses the patented AMP measurement method. With this method the insulation value can be reliably determined in DC systems with directly connected PV inverters.

Standards

The ISOMETER® of the isoPV485 series complies with the requirements of the device standards: DIN EN 61557-8 (VDE 0413-8), IEC 61557-8, IEC 61326-2-4 Ed. 1.0, DIN EN 60664-1 (VDE 0110-1), DIN EN 60664-3 (VDE 0110-3).

Warning!

This is a Class A device. If this device is used in a domestic environment radio interference may occur. In this case, the user may be required to take corrective actions.

Ordering information

Nominal system voltage ¹⁾ U_n		Supply voltage ¹⁾ U_s	Type	Art. No.
AC	DC	DC		
0...800 V	0...1000 V	12...72 V	isoPV485-421	B 9106 8144

¹⁾ Absolute values of the voltage ranges.

Dimension diagram X480

Dimensions in mm

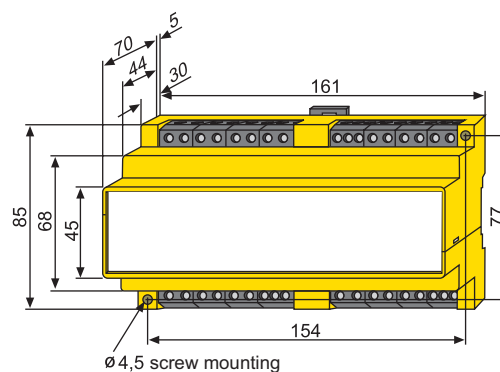

Operating elements

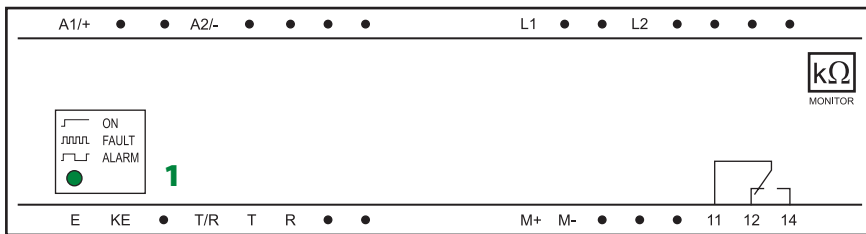

- 1 - Power On and alarm LED: lights when the device is in operation, flashes in case of alarm (0.3 Hz) or system faults (2 Hz)

Wiring diagram

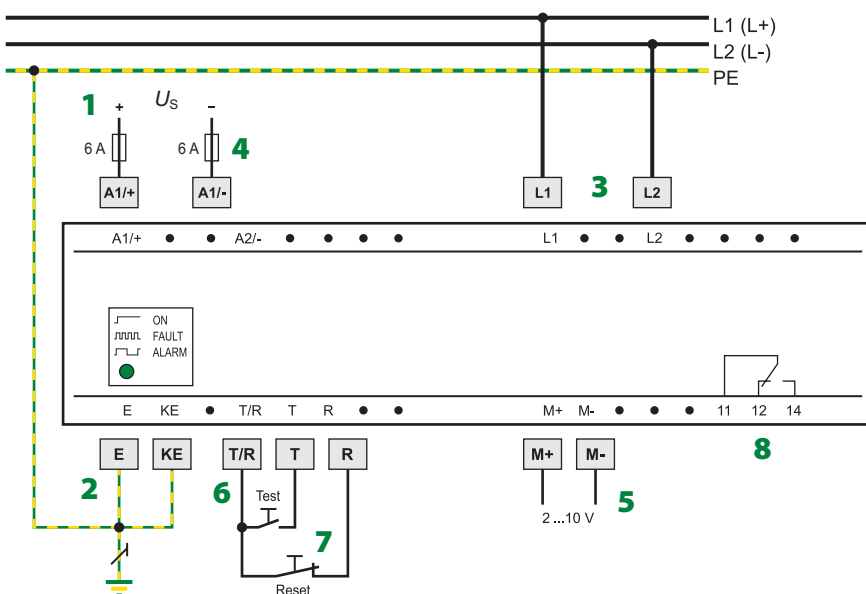

- 1 - Supply voltage U_s (see ordering information) via fuse
- 2 - Separate connection of E, KE to PE
- 3 - Connection of the AC system to be monitored, DC: Connect terminal L1, L2 to L+ and L-
- 4 - Line protection according to DIN VDE 0100-430/IEC 60364-4-43 (10 A, fast-acting, recommended). In case of supply (A1/A2) from an IT system, both lines have to be protected by a fuse.
- 5 - Voltage output 2...10 V (0...1 M Ω)
- 6 - Test button "T": Calls up the self test
- 7 - External reset button "R" (N/O contact or wire jumper), when the terminals R1/ R2 are open, the fault message will not be stored
- 8 - Alarm relay (N/C operation)

Typical application – Insulation monitoring in a photovoltaic system

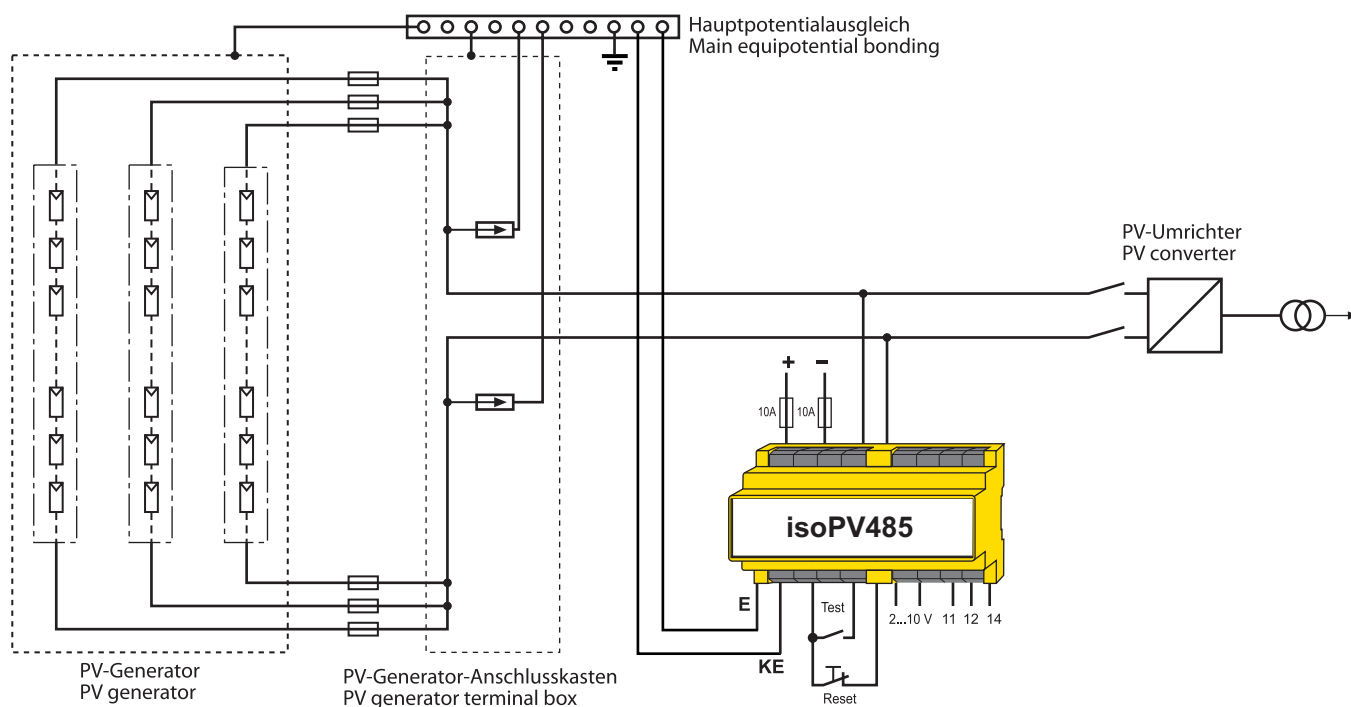

Technical data

Insulation coordination acc. to IEC 60664-1/IEC 60664-3

Rated insulation voltage	1000 V
Rated impulse voltage/pollution degree	8 kV/3
Protective separation (reinforced insulation) between (A1, A2) - (L1, L2, E, KE, T/R) - (11, 12, 14) - (M+, M-)	

Voltage ranges

Nominal system voltage U_n	DC 0...1000 V, AC 0...800 V
Nominal frequency f_n	42...460 Hz
Supply voltage U_s	DC 12...72 V
Power consumption	≤ 3.5 VA

Response values

Response value R_{an} (ALARM)	10 kΩ
Relative uncertainty	± 15 %
Response time t_{an} at $R_F = 0.5 \times R_{an}$ and $C_e = 1 \mu F$	≤ 90 s
Hysteresis	50%

Measuring circuit

Measuring voltage U_m	± 30 V
Measuring current I_m (at $R_F = 0 \Omega$)	≤ 150 μA
Internal DC resistance R_i	≥ 200 kΩ
Impedance Z_i at 50 Hz	≥ 200 kΩ
Permissible system leakage capacitance C_e	≤ 100 μF

Displays

LED, green	normal operation (lights continuously), alarm (0.3 Hz), system fault (2 Hz)
------------	---

Inputs/outputs

Test/reset button	external
Cable length test and reset button	≤ 10 m
Output signal at M+/M-	2...10 V (2 kΩ...10 MΩ)

Switching elements

Number of switching elements	1 changeover contact (11, 12, 14)				
Operating principle	N/C operation				
Contact data acc. to IEC 60947-5-1:					
Utilisation category	AC 13	AC 14	DC-12	DC-12	DC-12
Rated operational voltage	230 V	230 V	24 V	110 V	220 V
Rated operational current	5 A	3 A	1 A	0.2 A	0.1 A
Minimum contact rating	1 mA at AC/DC ≥ 10 V				

Environment/EMC

EMC	IEC 61326-2-4
Operating temperature	-25...+55 °C
Classification of climatic conditions acc. to IEC 60721:	
Stationary use (IEC 60721-3-3)	3K5 (except condensation and formation of ice)
Transport (IEC 60721-3-2)	2K3 (except condensation and formation of ice)
Long-time storage (IEC 60721-3-1)	1K4 (except condensation and formation of ice)
Classification of mechanical conditions acc. to IEC 60721:	
Stationary use (IEC 60721-3-3)	3M4
Transport (IEC 60721-3-2)	2M2
Storage (IEC 60721-3-1)	1M3

Connection

Connection	screw-type terminals
rigid/flexible	0.2...4/0.2...2.5 mm ² (AWG 24...12)
flexible with ferrule, without/with plastic sleeve	0.25...2.5 mm ²
Multi-conductor connection (two conductors with the same cross section)	
rigid/flexible	0.2...1.5/0.2...1.5 mm ²
Stripping length	8...9 mm
Tightening torque	0.5...0.6 Nm

Other

Operating mode	continuous operation
Mounting	any position
Degree of protection, internal components (DIN EN 60529)	IP30
Degree of protection, terminals (DIN EN 60529)	IP20
Enclosure material	polycarbonate
Type of enclosure	X480
Screw mounting	2 x M4
DIN rail mounting acc. to	IEC 60715
Flammability class	UL94 V-0
Operating manual	TBP106032
Weight	≤ 300 g



Bender GmbH & Co. KG

P.O.Box 1161 • 35301 Gruenberg • Germany
 Londorfer Straße 65 • 35305 Gruenberg • Germany
 Tel.: +49 6401 807-0 • Fax: +49 6401 807-259
 E mail: info@bender-de.com • www.bender-de.com

BENDERGroup