

## **LINETRAXX® RCMS150**

Residual current monitor type B with integrated measuring current transformers for earthed AC/DC systems (TN and TT systems)

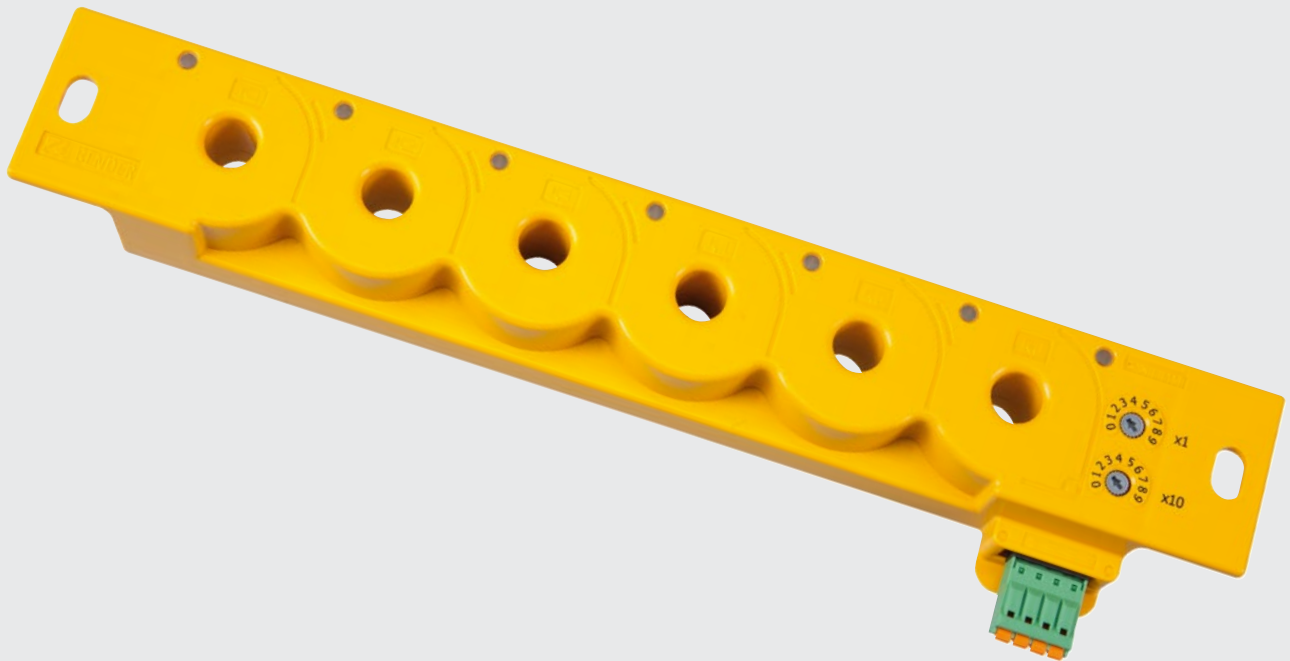

# LINETRAXX® RCMS150

**Residual current monitor type B  
with integrated measuring current transformers  
for earthed AC/DC systems (TN and TT systems)**



LINETRAXX® RCMS150

## Device features

- Continuous residual current monitoring in compliance with DGUV Vorschrift 3 (German Social Accident Insurance Regulation 3)
- AC/DC sensitive residual current monitor type B with 6 channels K1...6 (each channel features 2 measuring channels: 1 x RMS, 1 x DC)
- Compatible with RCMS460/490 in a system setup
- Ideal for applications with space limitations
- Easy DIN rail or screw mounting to standard distribution panels
- 2 separately adjustable response values (DC or r.m.s.) per channel
- Continuous self monitoring
- Fully shielded measuring current transformers to avoid external influences due to magnetic fields that may cause disturbances
- Compatible with Bender gateways of type COM465IP, CP700
- Up to 534 measuring channels in the monitored system that can be combined via BMS bus
- RS-485 interface with BMS bus (Modbus RTU on request)
- BMS address range 2...90

## Approvals and certifications

**UL508** in preparation

**CSA** in preparation

## Product description

The 6-channel residual current monitor RCMS150 is intended for measurement of AC and DC fault currents in earthed systems, which can emerge from insulation faults on loads with six-pulse rectifiers or one-way rectifiers with smoothing. The device can measure residual currents up to  $I_{\Delta} = 500$  mA in a frequency range of DC 0...2 kHz. Two separately adjustable response values allow a distinction to be made between prewarning and alarm.

The device features an RS-485 interface which can be used to transfer measured values and alarm values. Setting parameters is also possible via this interface.

## Intended use

The device RCMS150 is suitable for measuring residual currents up to  $I_{\Delta} = 500$  mA in a frequency range of DC 0...2 kHz. The monitored circuit is rated for a voltage of 300 V and a load current of 32 A. The device can be operated at an altitude of up to 2000 m above mean sea level.

## Function description

The residual currents are recorded and evaluated as r.m.s. values in the frequency range DC 0...2 kHz. The response values can be set via the connected gateways. The user can set four response values per channel 1...6:  $I_{\Delta n1}$  RMS,  $I_{\Delta n2}$  RMS,  $I_{\Delta n1}$  DC,  $I_{\Delta n2}$  DC.

If one of the four set response values  $I_{\Delta n...}$  is exceeded, the assigned response delay  $t_{on...}$  starts. If the response value continues to be exceeded, the corresponding message (prewarning or alarm) is displayed on the gateway after the response delay  $t_{on...}$  has elapsed. In the event of an alarm, the alarm LED of the respective channel K1...6 lights up yellow.

If the recorded residual current falls below the release value (response value minus hysteresis) the delay on release  $t_{off}$  begins. If the value remains below the release value after  $t_{off}$  has elapsed, the message on the gateway is reset. If the alarm LED of the respective channel has been lit, now it goes out.

A pending response value violation is emitted via the BMS interface with address and measuring channel indication and can be evaluated by means of a gateway.

All devices can be accessed via the network from any PC using a standard web browser (Firefox, Internet Explorer). Like this, all relevant measurement data of the monitored system are available. All device-related parameters of the RCMS150 can be set via the gateway technology.

To ensure the device function, a continuous automatic self test is run, which monitors the function of all measuring current transformers. In the event of a device error, all alarm LEDs flash.

Display and operating controls

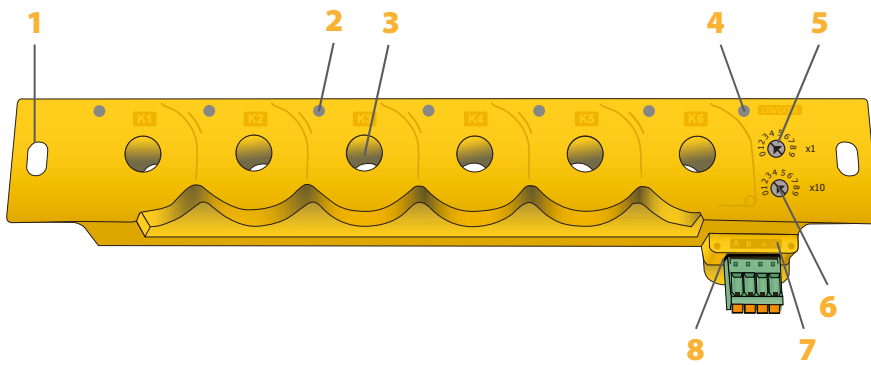

- 1 - Slot for screw mounting
- 2 - Alarm LEDs for the measuring channels K1...6
- 3 - Line feed-through of the measuring current transformers for the measuring channels K1...6
- 4 - ON LED: Power On LED
- 5 - Determination of ones' position of the BMS address
- 6 - Determination of tens' position of the BMS address
- 7 - Connection to the supply voltage
- 8 - Connection RS-485, BMS bus

Wiring diagram

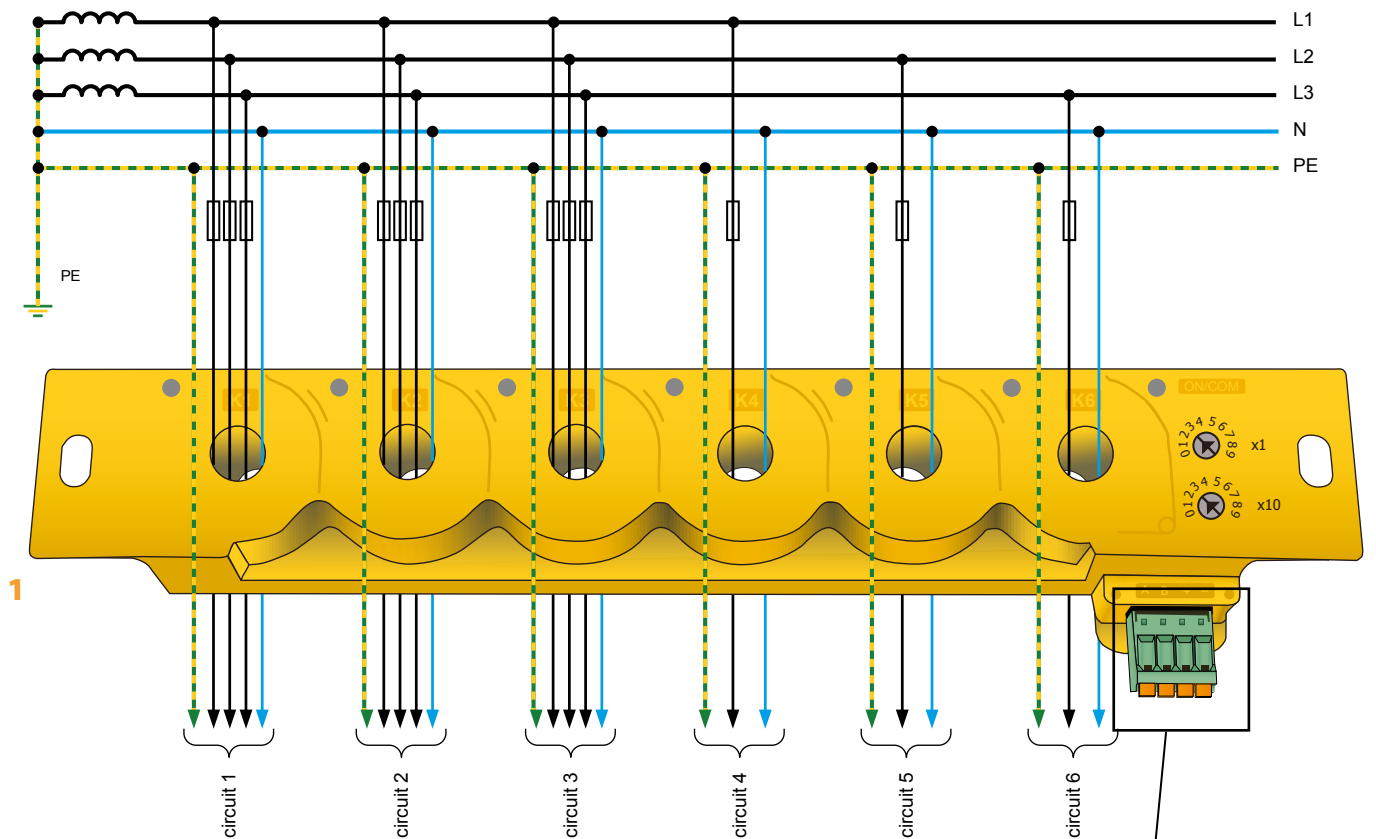

- 1 - Residual current monitor RCMS150
- 2 - Supply voltage  $U_s$  DC 24 V
- 3 - RS-485 interface with BMS bus (Modbus RTU on request)
- 4 - Terminating resistor (required at the beginning and at the end of the bus)



Note:

Only insulated primary conductors suited for the indicated rated voltages are to be used!

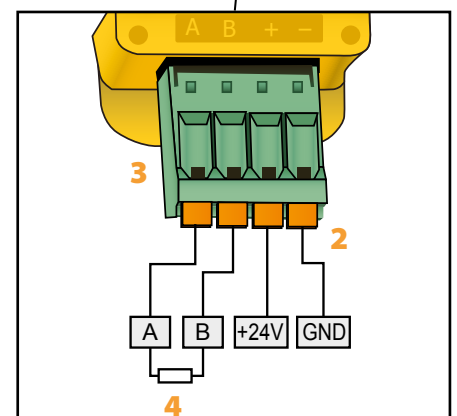

## Technical data

### Insulation coordination according to IEC 60664-1

#### The data are valid for the monitored primary circuit to the output circuit

Output circuit	(+, -, A, B)
Rated insulation voltage	300 V
Overvoltage category	III
Rated impulse withstand voltage monitored circuit/output circuit	4 kV
Range of use	≤ 2000 m AMSL
Rated insulation voltage	250 V
Pollution degree	3
Insulation	BI: Overvoltage category III DI: Overvoltage category II

To achieve double insulation (DI) for overvoltage category III, insulated primary conductors with sufficient rated voltage must be used on the application side.

Voltage test acc. to IEC 61010-1 AC 2.2 kV

### Power supply

Nominal supply voltage $U_s$ with galvanic separation	DC 24 V
Power consumption	< 4 W

### Residual current measuring range

Frequency range	0...2000 Hz
Measuring range	±500 mA
Resolution measured value	1 % of the set response value

### Response values

Residual current $I_{\Delta N2}$	RMS 0...300 mA (30 mA)*
Residual current $I_{\Delta N2}$	DC 3...300 mA (6 mA)*
Ratio $I_{\Delta N2 \text{ RMS}}/I_{\Delta N2 \text{ DC}}$	0.2...5
Prewarning $I_{\Delta N1 \text{ RMS/DC}}$	50...100 % (50 %)*
Response tolerance $I_{\Delta N2}$	
DC 10...500 Hz	-20...0 %
500 Hz...2 kHz	-20...+100 %
Hysteresis	10...25 % (15 %)

### Time response

Start-up delay $t_{\text{start-up}}$	0.5...600 s (0.5 s)*
Response delay	
$t_{\text{on1 RMS/DC}}$	0...600 s (0 s)*
$t_{\text{on2 RMS/DC}}$	0...600 s (0 s)*
Delay on release	
$t_{\text{off1 DC}}$	0...600 s (1 s)*
$t_{\text{off2 RMS}}$	0...600 s (1 s)*

### Indication (LEDs)

#### ON

green	normal operation indication
green (flashing quickly)	internal device fault or BMS bus address set incorrectly
green (flashing slowly)	indication BMS bus address (after device start/address modification)

#### ALARM K1...6

yellow	$I_{\Delta} > I_{\Delta n}$
yellow (flashing)	measured value range exceeded

### Interface

Interface/protocol	RS-485/BMS
Connection	terminals A/B
Shielded cable (one end of shield connected to PE)	twisted pair, e.g.: J-Y(St)Y 2x0.8
Cable length	≤ 1200 m
Bus terminating resistor external	120 Ω (0.25 W)
Device address, BMS bus	2...90 (2)*

### Environment/EMC

EMC immunity	IEC 61000-6-2
emission	IEC 61000-6-3
Operating temperature	-25...+70 °C
Classification of climatic conditions acc. to IEC 60721:	
Stationary use (IEC 60721-3-3)	3K5
Transport (IEC 60721-3-2)	2K3
Long-term storage (IEC 60721-3-1)	1K4
Classification of mechanical conditions acc. to IEC 60721:	
Stationary use (IEC 60721-3-3)	3M4
Transport (IEC 60721-3-2)	2M2
Long-term storage (IEC 60721-3-1)	1M3

### Connection

Connection type	pluggable push-wire terminal
Connection properties:	
rigid, flexible/conductor sizes AWG	0.2...1.5 mm <sup>2</sup> /AWG 24...16
Multi-conductor connection (2 conductors with the same cross section):	
rigid	0.2...1.5 mm <sup>2</sup>
flexible	0.2...1.5 mm <sup>2</sup>
flexible with ferrule without plastic sleeve	0.25...1.5 mm <sup>2</sup>
flexible with ferrule with plastic sleeve	0.25...0.75 mm <sup>2</sup>
Stripping length	10 mm

### Other

Operating mode	continuous operation
Position of normal use	any
Enclosure material	polycarbonate
Flammability class	UL94 V-0
Screw mounting to standard distribution panels with 12 TE	2 x M6
DIN rail mounting	mounting clip (accessories)
Tightening torque	1.5 Nm
Documentation number	D00259
Weight	170 g

### Measuring current transformer

Diameter cable gland	10 mm
Load current	32 A

### Bus parameter

Alarm	threshold value exceeded, system fault
Measured value	measured value, DC component, r.m.s. (resolution 0.1 mA)
Times	response delay, delay on release, start-up delay

( ) \* = factory settings

**Example for a system design**

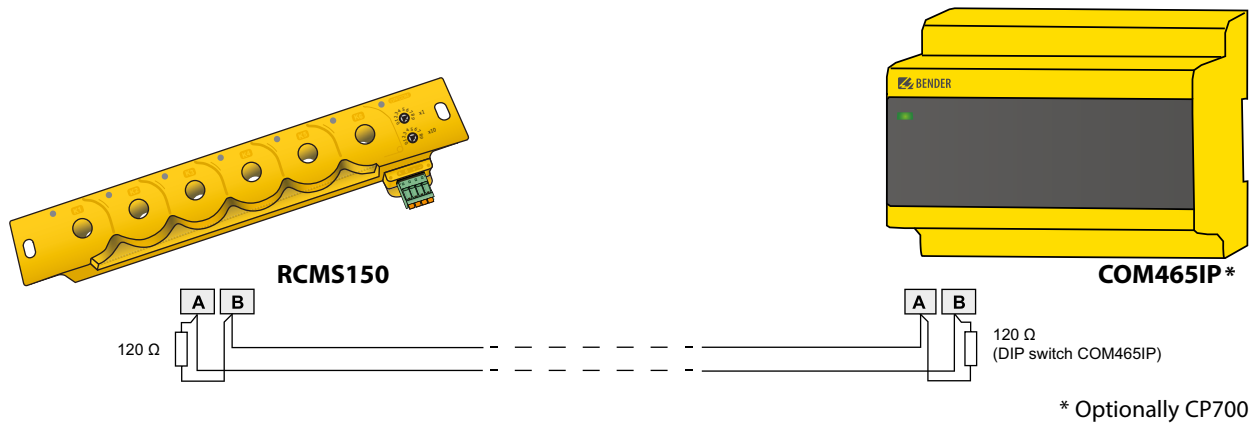

**Ordering information**

Nominal supply voltage $U_S$	Type	Art. No.
DC	RCMS150	B 9405 3025
24V		

**Accessories**

Description	Art. No.
Mounting clip for DIN rail mounting	B 9108 0110

**Suitable system components**

Description	Type	Art. No.
Condition Monitor with integrated gateway	COM465IP <sup>1)</sup>	B 9506 1065
Condition Monitor	CP700 <sup>1)</sup>	B 9506 1030
RS-485 repeater	DI-1DL	B 9501 2047
Power supply	AN410	B 924 209
Residual current monitor <sup>2)</sup>	RCMS460-D-1	B 9405 3001
	RCMS460-D-2	B 9405 3002
	RCMS490-D-1	B 9405 3005
	RCMS490-D-2	B 9405 3006

<sup>1)</sup> from function module C

<sup>2)</sup> suitable for measured value and alarm indication only, not suitable for parameter setting

**Dimension diagram**

Dimensions in mm

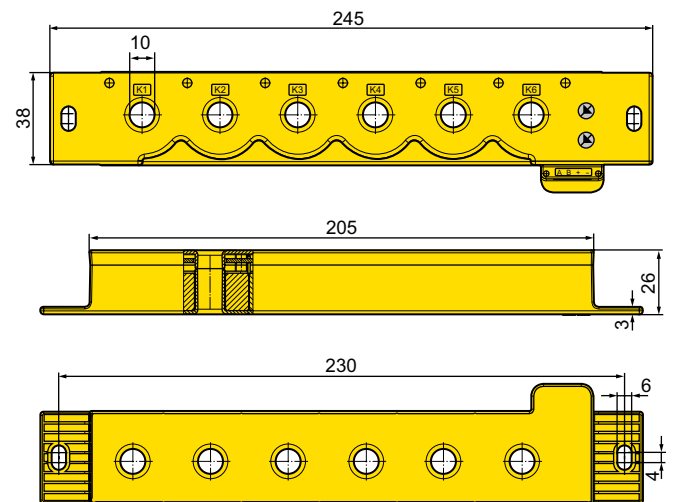



**Bender GmbH & Co. KG**

P.O. Box 1161 • 35301 Grünberg • Germany

Londorfer Straße 65 • 35305 Grünberg • Germany

Tel.: +49 6401 807-0 • Fax: +49 6401 807-259

E-mail: [info@bender.de](mailto:info@bender.de) • [www.bender.de](http://www.bender.de)



**BENDER Group**